

# CDP-990

## SERVICE MANUAL

US Model  
Canadian Model  
AEP Model  
UK Model  
E Model  
Australian Model



Model Name Using Similar Mechanism	New
CD Mechanism Name	CDM11C-5H
Base Unit Name	BU-5H

### SPECIFICATIONS

#### Compact disc player

Frequency response	2 Hz - 20 kHz $\pm$ 0.5 dB
Signal to noise ratio	More than 112 dB
Dynamic range	More than 100 dB
Harmonic distortion	Less than 0.003%
Channel separation	More than 100 dB

#### Outputs

LINE OUT (FIXED) (phono jacks)	Output level 2 V (at 50 kilohms) Load impedance over 10 kilohms
LINE OUT (VARIABLE) (phono jacks)	Output level max. 2 V (at 50 kilohms) Load impedance over 50 kilohms
DIGITAL OUT (OPTICAL) (optical output connector)	Wave length 660 nm Output level -18 dBm
HEADPHONES (Stereo phone jack)	Output level max. 28 mW Load impedance 32 ohms

#### General

Power requirements	AEP Model : 220 V AC (or 240 V AC adjustable by Sony personnel), 50/60 Hz UK Model : 240 V AC (or 220 V AC adjustable by Sony personnel), 50/60 Hz Australian Model : 240 V AC, 50/60 Hz US, Canadian Models : 120 V AC, 60 Hz E Model : 110, 120, 220, or 240 V AC adjustable, 50/60 Hz
Power consumption	17 W
Dimensions (approx., including projections)	430 $\times$ 115 $\times$ 340 mm (w/h/d) (17 $\times$ 4 $\frac{1}{2}$ $\times$ 13 $\frac{3}{5}$ inches)
Weight (approx.)	5.3 kg (11 lbs 11 oz)

#### Remote commander (RM-D590)

Remote control system	Infrared control
Power requirements	3 V DC with two batteries size AA (IEC designation R6)
Dimensions	67 $\times$ 18 $\times$ 175 mm (w/h/d) (2 $\frac{3}{4}$ $\times$ 2 $\frac{2}{3}$ $\times$ 7 inches)
Weight	150 g (5.3 oz) Including batteries

#### Supplied accessories

Connecting cord	1 (2 phono plugs $\leftrightarrow$ 2 phono plugs)
Remote commander	1
R6 (size AA) batteries	2

#### Optional accessory

Audio optical connecting cord POC-15

Design and specifications subject to change without notice.



COMPACT DISC PLAYER  
**SONY**®

TABLE OF CONTENTS

<u>Section</u>	<u>Title</u>	<u>Page</u>	<u>Section</u>	<u>Title</u>	<u>Page</u>
SPECIFICATIONS	.....	1	<b>4. DIAGRAMS</b>		
MODEL IDENTIFICATION	.....	2	4-1.	CIRCUIT BOARDS LOCATION	22
SAFETY CHECK-OUT	.....	3	4-2.	SEMICONDUCTOR LEAD LAYOUTS	22
SERVICING NOTES	.....	3	4-3.	Description on IC101 (CXA1372Q)	23
<b>1. GENERAL</b>			4-4.	Description on IC801 (MSC62408-003GS-K)	25
1-1.	Location and Function of Controls	5	4-5.	Description on IC301 (M37450M8-130FP)	27
1-2.	Operating Instructions (Extracted from Instruction Manual)	6	4-6.	BLOCK DIAGRAM	29
<b>2. DISASSEMBLY</b>			4-7.	PRINTED WIRING BOARDS (MAIN BOARD suffixed 13 )	32
2-1.	Removal of LOADING PANEL	18	4-8.	SCHEMATIC DIAGRAM (US Model) • WAVEFORM	35
2-2.	Removal of CD MECHANISM BLOCK (CDM11C-5H)	18	4-9.	SCHEMATIC DIAGRAM (Except US Model)	38
2-3.	Removal of BASE UNIT (BU-5H)	18	4-10.	PRINTED WIRING BOARDS (MAIN BOARD suffixed 11 ) • IC BLOCK DIAGRAM	41
2-4.	Removal of MOTOR ASSY	19			43
2-5.	Removal of OPTICAL PICK-UP BLOCK (KSS-240A)	19			
2-6.	Removal of DISK TABLE and BELT	19	<b>5. EXPLODED VIEWS</b>		
<b>3. ELECTRICAL ADJUSTMENTS</b>	.....	20	5-1.	OVERALL SECTION	45
			5-2.	MD SECTION (CDM11C-5H)	47
			5-3.	OPTICAL PICK-UP BLOCK (BU-5H)	48
			<b>6. ELECTRICAL PARTS LIST</b>	.....	49

MODEL IDENTIFICATION

- Specification Labels -

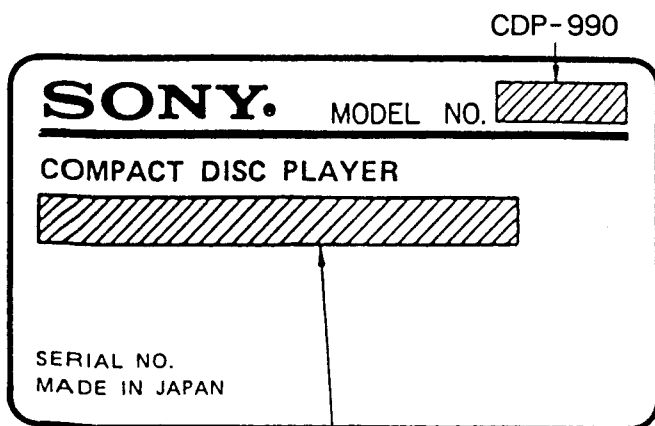

US, Canadian Models : AC : 120V 60Hz 17W  
 AEP Model : AC : 220V ~50/60Hz  
 UK, Australian Models : AC : 240V ~50/60Hz  
 E Model : AC : 110, 120, 220, 240V  
 ~50/60Hz 17W

**SAFETY-RELATED COMPONENT WARNING!!**  
 COMPONENTS IDENTIFIED BY MARK  $\Delta$  OR DOTTED LINE WITH MARK  $\Delta$  ON THE SCHEMATIC DIAGRAMS AND IN THE PARTS LIST ARE CRITICAL TO SAFE OPERATION. REPLACE THESE COMPONENTS WITH SONY PARTS WHOSE PART NUMBERS APPEAR AS SHOWN IN THIS MANUAL OR IN SUPPLEMENTS PUBLISHED BY SONY.

**ATTENTION AU COMPOSANT AYANT RAPPORT À LA SÉCURITÉ!**  
 LES COMPOSANTS IDENTIFIÉS PAR UNE MARQUE  $\Delta$  SUR LES DIAGRAMMES SCHÉMATIQUES ET LA LISTE DES PIÈCES SONT CRITIQUES POUR LA SÉCURITÉ DE FONCTIONNEMENT. NE REMPLACER CES COMPOSANTS QUE PAR DES PIÈCES SONY DONT LES NUMÉROS SONT DONNÉS DANS CE MANUEL OU DANS LES SUPPLÉMENTS PUBLIÉS PAR SONY.

## SAFETY CHECK-OUT (US, Canadian models)

After correcting the original service problem, perform the following safety check before releasing the set to the customer:

Check the antenna terminals, metal trim, "metallized" knobs, screws, and all other exposed metal parts for AC leakage. Check leakage as described below.

### LEAKAGE TEST

The AC leakage from any exposed metal part to earth ground and from all exposed metal parts to any exposed metal part having a return to chassis, must not exceed 0.5 mA (500 microampers). Leakage current can be measured by any one of three methods.

1. A commercial leakage tester, such as the Simpson 229 or RCA WT-540A. Follow the manufacturers' instructions to use these instruments.
2. A battery-operated AC milliammeter. The Data Precision 245 digital multimeter is suitable for this job.
3. Measuring the voltage drop across a resistor by means of a VOM or battery-operated AC voltmeter. The "limit" indication is 0.75 V, so analog meters must have an accurate low-voltage scale. The Simpson 250 and Sanwa SH-63Trd are examples of a passive VOM that is suitable. Nearly all battery operated digital multimeters that have a 2V AC range are suitable. (See Fig. A)

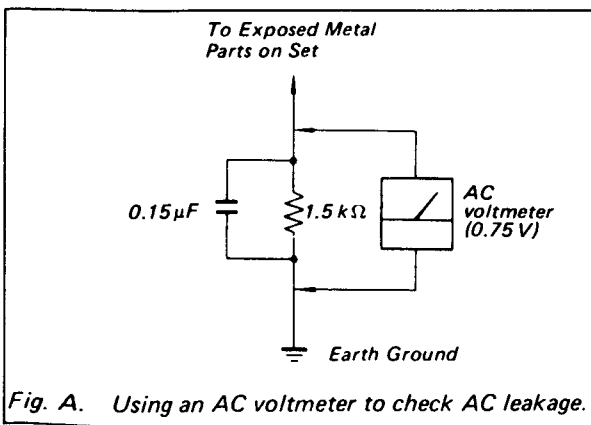

### NOTES ON HANDLING THE OPTICAL PICK-UP BLOCK OR BASE UNIT

The laser diode in the optical pick-up block may suffer electrostatic breakdown because of the potential difference generated by the charged electrostatic load, etc. on clothing and the human body.

During repair, pay attention to electrostatic breakdown and also use the procedure in the printed matter which is included in the repair parts.

The flexible board is easily damaged and should be handled with care.

### NOTES ON LASER DIODE EMISSION CHECK

The laser beam on this model is concentrated so as to be focused on the disc reflective surface by the objective lens in the optical pick-up block. Therefore, when checking the laser diode emission, observe more than 30 cm away from the objective lens.

### E MODEL :

**For the customers of the model equipped with the voltage selector**

Check that the voltage selector is set to the local power line voltage. If not, set the selector to the correct position before connecting the AC power cord to a wall outlet.

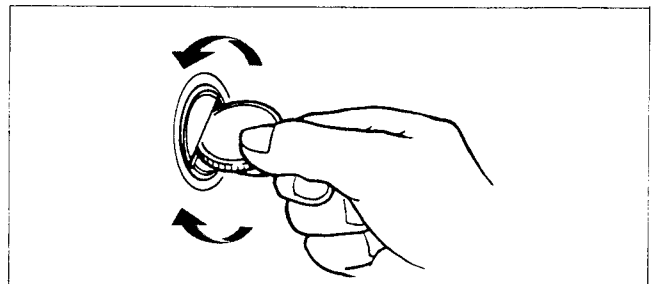

## PROTECTION OF EYES FROM LASER BEAM DURING SERVICING

This set employs a laser. Therefore, be sure to follow carefully the instructions below when servicing.

### CAUTION

Use of controls or adjustments or performance of procedures other than those specified herein may result in hazardous radiation exposure.

### 1. Laser Diode Properties

- Material: GaAlAs
- Wavelength: 780 nm
- Emission Duration: continuous
- Laser Output: max. 44.6  $\mu$ W\*

\* This output is the value measured at a distance of about 200 mm from the objective lens surface on the Optical Pick-up Block.

2. During service, do not take the Optical Pick-up Block apart, and do not adjust the APC circuit. If there is a breakdown in the APC circuit (including laser diode), replace the entire Optical Pick-up Block (including APC board).

---

## BESKYTTELSE AF ØJNE MOD LASERSTRÅLING UNDER SERVICE

I dette apparat anvendes laserlys. Derfor skal nedenstående instruktioner nøje følges under service.

Følg iverigt instruktionerne i servicemanualen.

### ADVARSEL!!

Under service må øjnene ikke komme nær objektiv-linsen på den optiske pick-up enhed. I tilfælde af at det er nødvendigt at kontrollere udsendelsen af laserlys, skal det ske i en afstand af mere end 25 cm fra den optiske pick-up.

### 1. Laser-dioe data

- Materiale: GaAlAs
- Bølgelængde: 780 nm
- Udstråling: Kontinuerlig
- Laseroutput: Max. 0,4 mW\*

\* Målt i 1,6 mm afstand fra overfladen af objektiv-linsen på den optiske pick-up enhed.

- Klassifikation: Klasse IIIb.

2. Adskil aldrig den optiske pick-up enhed under service, og juster ikke APC kredsløbet (Automatic Power Control). Hvis APC kredsløbet (incl. laserdioden) bryder ned, skal hele den optiske pick-up enhed (incl. APC printkortet) udskiftes.

## LASER ADVARSEL MÆRKNING

Følgende mærkning findes indvendig i apparatet:

### 1. Advarsel Mærkning

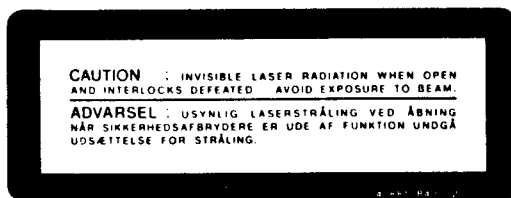

**VAROITUS:** Laite sisältää, laserdiodin, joka lähettää (näkyvätöntä) silmille vaarallista lasersäteilyä.

## SECTION 1 GENERAL

### 1-1. Location and Function of Controls

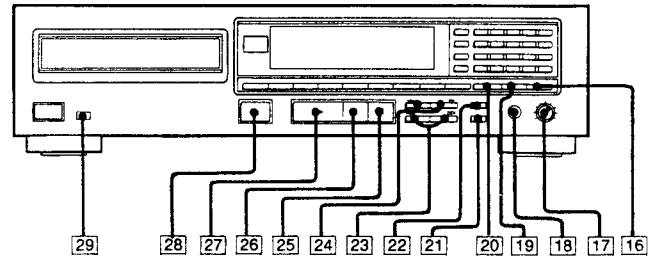
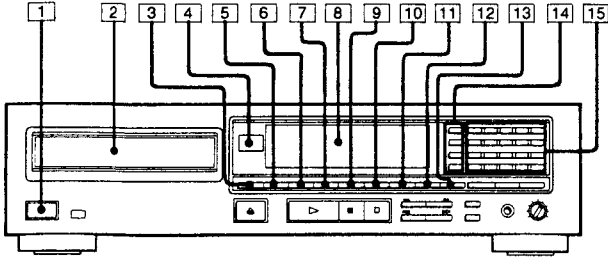

- 1 POWER switch
- 2 Disc tray
- 3 TIME/MEMO button
- 4 Remote sensor
- 5 PEAK SEARCH button
- 6 REPEAT button
- 7 FADER (fade in/fade out) button
- 8 Display window
- 9 CHECK (program check) button
- 10 CLEAR (program clear) button
- 11 FILE (custom file) button
- 12 ERASE (memory erase) button
- 13 MULTI PGM button
- 14 Play mode buttons  
CONTINUE button  
SHUFFLE button  
PROGRAM button  
C. (custom) INDEX button

- 15 Numeric buttons
- 16 LEVEL FILE button
- 17 LINE OUT/PHONE LEVEL control
- 18 PHONES jack
- 19 > 20 (over 20) button
- 20 FILE RECALL button
- 21 TIME SET button
- 22 EDIT/TIME FADE button
- 23 <<<>>> (AMS\*) buttons
- 24 <<<>>> (manual search) buttons
- 25 ■ (stop) button
- 26 || (pause) button
- 27 ▶ (play) button
- 28 ▲ (open/close) button
- 29 TIMER switch

\* AMS is the abbreviation of Automatic Music Sensor.

### Remote Commander (RM-D590)

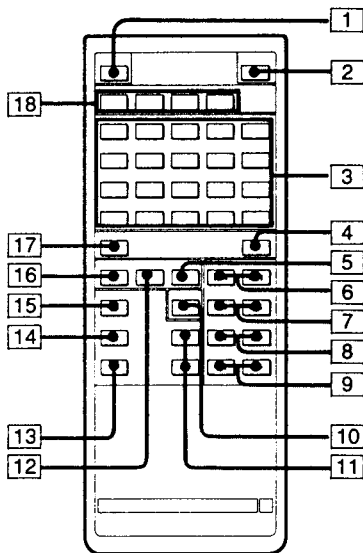

- 1 ▲ (open/close) button
- 2 DISPLAY MODE button
- 3 Numeric buttons
- 4 FILE (custom file) button
- 5 AUTO SPACE (auto space) button
- 6 <<<>>> AMS buttons
- 7 < - > INDEX buttons
- 8 <<<>>> (manual search) buttons
- 9 <<<>>> SLOW (low speed manual search) buttons
- 10 FADER (fade in/fade out) button
- 11 LINE OUT VOLUME (line out/headphone volume) buttons
- 12 A ↔ B repeat button
- 13 ■ (stop) button
- 14 || (pause) button
- 15 ▶ (play) button
- 16 CLEAR/REPEAT (A ↔ B repeat clear/repeat) button
- 17 > 20 (over 20) button
- 18 PLAY MODE buttons  
CONTINUE button  
SHUFFLE button  
PGM (program) button  
C.INDEX button

## 1-2. Operating Instructions (Extracted from instruction Manual)

### Connecting the CD Player

You can connect the unit with analog or digital signal depending on your amplifier or D/A converter.

#### Notes on Connection

- Turn off the power of each unit before making connections.
- Connect the AC power cord last. For the model supplied with the plug adaptor, use it if the plug of the power cord does not match your wall outlet.
- Be sure to insert the plugs firmly into the jacks. Loose connection may cause hum and noise.
- Leave a little slack in the connecting cord to allow for inadvertent shock or vibration.
- Cord plugs and jacks are color coded: Red plugs and jacks are for the right channel (R) and white ones for the left channel (L).

#### Notes on LINE OUT

- Normally connect the cable to FIXED. (The output level is fixed.)  
Control the volume with the amplifier's volume control. To use the level file function, connect the cable to VARIABLE.

- When you connect the unit to a power amplifier, connect the cable to VARIABLE and control the volume with the LINE OUT/PHONE LEVEL control. However, if the LINE OUT/PHONE LEVEL control is turned while recording, the recording level will change even when it is preset on the tape deck.

#### Note on DIGITAL OUT

When connecting with DIGITAL OUT (OPTICAL), use the POC-15 audio optical connecting cord (optional). Please note that when the digital out is connected, fade out, fade in, time fade and level file functions cannot be used.

### Preparing the Remote Commander

#### On battery life

- About half a year of normal operation can be expected when using the Sony SUM-3(NS) batteries.
- When the batteries are run down, the remote commander will not operate the unit. In this case, replace both batteries with new ones.

#### Notes on the remote commander and remote control operation

- Keep the commander away from extremely hot or humid places.
- Avoid dropping any foreign objects into the commander casing, particularly when replacing the batteries.
- Avoid exposing the remote sensor to direct sunlight or lighting apparatus. Such exposure can cause a malfunction.
- To avoid damage caused by battery leakage and corrosion, remove the batteries when the commander will not be used for a long time.

1

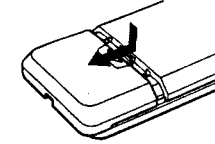

2

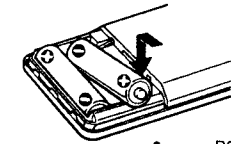

R6 (AA) × 2

### Connecting Directly to an Amplifier

#### OPTICAL DIGITAL OUT

When connecting to an amplifier or D/A converter with OPTICAL IN, use OPTICAL DIGITAL OUT instead of LINE OUT.

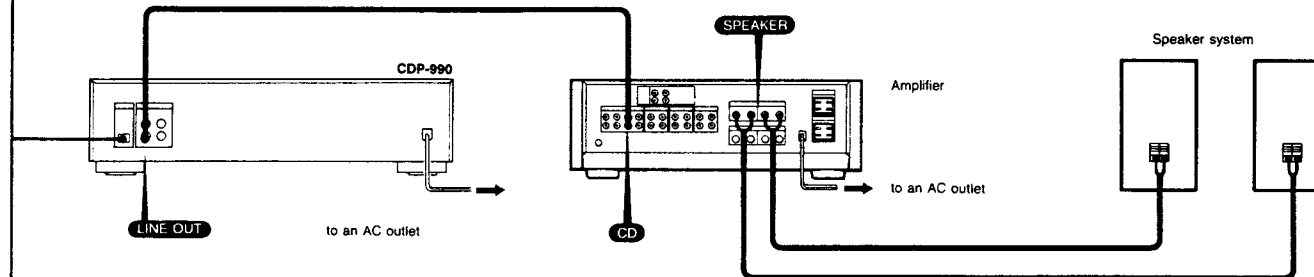
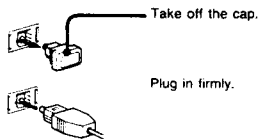

## Playing a Disc

Before playing a disc, turn on the amplifier and set the input selector to the CD player position.

**To take out the disc**  
Press .

**To play an 8 cm (3-inch) CD**  
Place it on the inner circle of the tray. If the disc is provided with an adaptor, first remove it. Do not put a normal CD (12 cm/5-inch) on top of an 8 cm CD.

### Notes on handling discs

- To keep the disc clean, handle the disc by its edge. Do not touch the surface.



- Do not stick paper or tape on the disc.



- Do not expose the disc to direct sunlight or heat sources such as hot air ducts, or leave it in a car parked in direct sunlight as there can be a considerable rise in the temperature.
- After playing, store the disc in its case.

## Playing the Entire Disc

### Caution on adjusting volume

Do not turn up the volume while listening to a portion with very low level inputs or no audio signals. If you do, the speakers may be damaged when a peak level portion is played.

### To stop play

To stop for a moment during play, press .

Press  or  to resume play.

To stop play, press .

To stop play and open the tray, press .

### When listening with headphones

Connect the headphones and control the volume with LINE OUT/PHONE LEVEL control or LINE OUT VOLUME of the remote commander.

### To control the volume

When you use VARIABLE, control the volume with LINE OUT/PHONE LEVEL control of the player or LINE OUT VOLUME of the remote commander. Press + of the remote commander to turn up the volume and press - to turn down the volume. When you press + or -, the LINE OUT/PHONE LEVEL control of the player rotates automatically.

### Note on the TIMER switch

Leave the TIMER switch off when not setting timer activated play. (For further details, refer to page 72).

### If a disc contains more than 20 selections

 appears in the display window instead of the total number of selections.

### What is this indication?

--NO DISC--

This indication appears when there is no disc in the disc compartment.

The indication can be changed to a desired indication. (page 62)

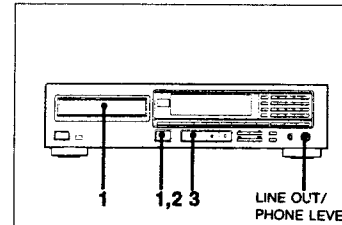

## Inserting a Disc

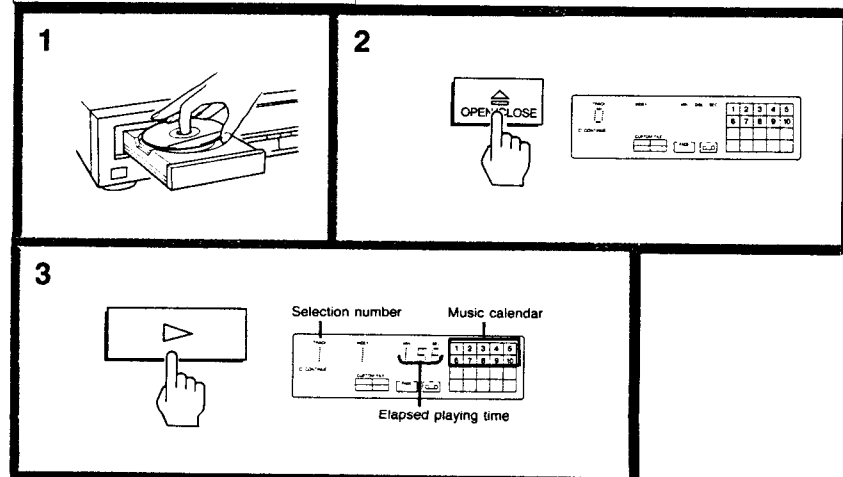
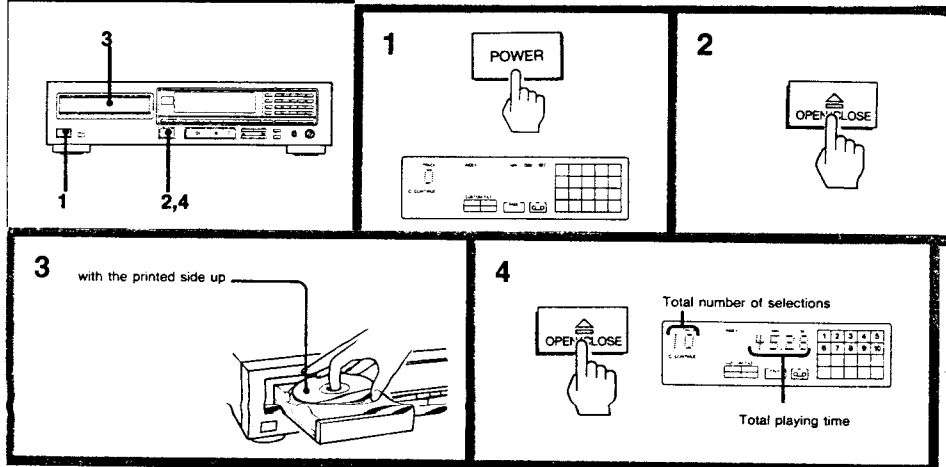

**Information display**



Each time you press TIME/MEMO during play, the display changes to give you the following information.

- A Elapsed playing time
- B Remaining time in a selection  
If the current selection number is over 25, "-----" is displayed.
- C Remaining number of selections and total remaining time.

**If you have stored a disc memo**

The stored disc memo will be displayed, following the display of the remaining time of the disc.

**To change the parts of information display**



Each time you press the DISPLAY MODE on the remote commander during play, the display changes to give you the following information

→ Entire display ON → Track number, Play mode and Music calendar ON → Entire display OFF

**Locating a Particular Selection**

You can locate the beginning of a desired selection during play or pause.

**To locate sequentially**

**To locate the beginning of the current or preceding selection**

- Press ◀◀ as many times as required.
- Keep ◀◀ pressed to skip selections.

**To locate the beginning of a succeeding selection**

- Press ▶▶ as many times as required.
- Keep ▶▶ pressed to skip selections.

**To locate directly**

Press one of the numeric buttons ( [1] to [20] ) to enter the desired selection number.

If a selection number is greater than 20, use the >20 and [1] to [10] buttons. [10] functions as the figure 0.

e.g. To play from selection No.22 Press >20 [2] [2]  
To play from selection No.30 Press >20 [3] [10]

**Locating a Particular Point in a Selection**

You can locate a particular point in the disc during play.

**To search quickly while monitoring the sound**

**To go ahead at high speed**

Keep ▶▶ pressed during play and release at the desired point.

**To go back at high speed**

Keep ◀◀ pressed during play and release at the desired point.

**To search quickly by observing the display**

Press ||, then keep ◀◀ or ▶▶ pressed. The search speed will increase, but there will be no sound. Find the desired point by observing the display.

Press || or ▶ again at the desired point.

**To search slowly while monitoring the sound**



Press ◀◀/▶▶ SLOW during play and release at the desired point.

**"OVER" is displayed**

If you continuously press ▶▶ at the end of the disc, "OVER" appears in the window. Press ◀◀ or ◀ to return to normal indication.

If you continuously press ◀◀ at the beginning of the disc, play begins automatically from the first selection.

**Locating an Index**



This function is only possible with a disc on which index numbers are recorded.

**What is an index?**

This is a number assigned to a section of a selection (for example, to a movement in a symphony) to allow that section to be located easily.

Press ← or → to locate the desired index number.

The selected index number appears in the display window.

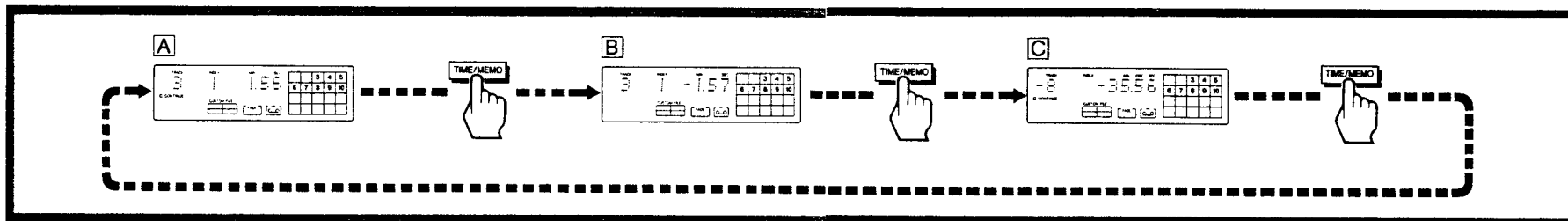



## Playing in a Random Order - Shuffle Play

You can have the selections played in a random order. The unit will play all the selections, or just the selections you desire.

**To stop playing**  
Press ■

**To cancel shuffle play**  
Press CONTINUE and return to the continuous playing mode.

**To check the remaining time**  
Press TIME/MEMO once to see the remaining time of the selection being played; twice to see the total remaining time; once more to return to the initial display.

**If you press SHUFFLE during play**  
Shuffle play begins from the current selection.

**What is this indication?**  
 This indication appears while the player is "shuffling" the selections.

**To play only the desired selections in a random order - Delete Shuffle Play**  
Delete the undesired selections before or during play.

**To delete a selection**, press the numeric button for that selection. "DELETE" will be displayed in the window. You cannot delete a selection which is being played. To choose a selection number over 20, see page 26.

**To put back a selection which you have deleted**, press the numeric button for that selection. "SELECT" will be displayed in the window.

**To put back all selections which you have deleted**, press ■ during stop.

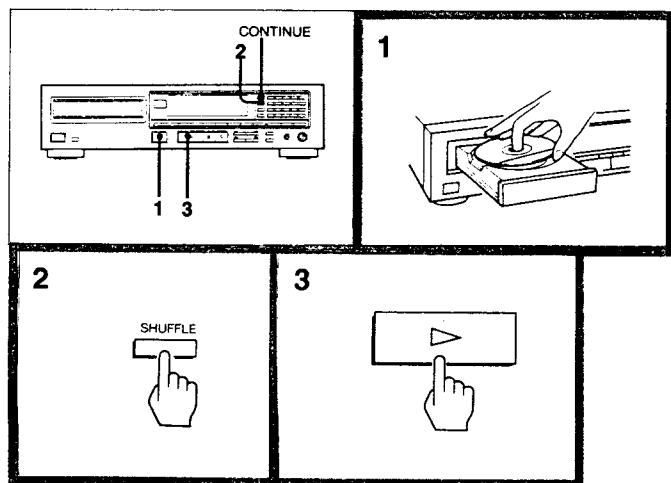

## Playing Repeatedly - Repeat Play

### Repeating Selections

Press REPEAT (or CLEAR/REPEAT on the remote commander) before or during play. "REPEAT" appears. The unit repeats the current playing mode. To repeat a single selection, press REPEAT (or CLEAR/REPEAT on the remote commander) again during repeat play of the continuous play. "REPEAT 1" appears.

Playing mode	Selections to be repeated
Continuous play	All the selections or the current selection.
Shuffle play Delete shuffle play	Selections that the player reshuffles
Program play	All the selections programmed in the same order
Custom index play	Between the specific custom indexes

**Note**  
Repeat play cannot be conducted on multi-disc programs.

**To cancel repeat play**  
Press REPEAT (or CLEAR/REPEAT on the remote commander) again. "REPEAT" disappears. To cancel repeat play of the continuous play mode, press REPEAT twice. "REPEAT" disappears.

### Repeating a Particular Portion - A → B Repeat

You can repeat a portion on the disc by designating the starting point (A) and the ending point (B).

**To cancel A → B repeat**  
Press CLEAR/REPEAT (or REPEAT on the player).

**Going back to the same point (A) from any point on the disc**

Press A → B to designate the desired point (A). (Point B need not be designated.) You can go back to point A from any point on the disc by simply pressing ►.

**When you designate A → B repeat during shuffle or program play**  
You cannot designate point A and B in two different selections.

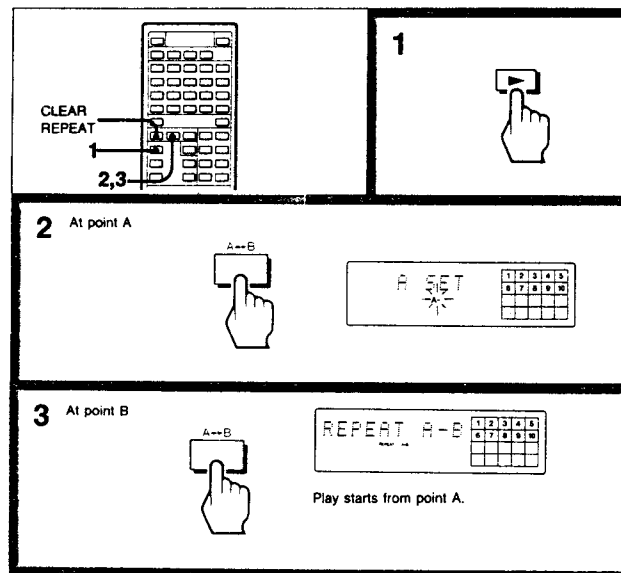

## Playing in a Desired Order

### - Program Play

You can make a program by designating up to 24 selections in the order you want them to be played. The unit will play the disc according to your program.

\* To choose a selection number over 20, see page 26.

#### To stop playing

Press **■**.

You can play the same program repeatedly as long as you do not cancel program play or erase the program.

#### To cancel program play

Press CONTINUE and return to the continuous playing mode.

The program will be erased.

#### To erase the entire program

Press **■** once during stop; twice during play.

The program is also erased when you turn off the unit.

#### To make a program for editing a tape

You can insert a pause in your program. Use this function to make a program for both sides of the tape at one time.

1 Program the selections for side A.

2 Press **■**. "P" will be displayed and the total playing time will be reset to 0.



"B" lights up.

3 Program the selections for side B.

When you start playing, the selections for side A will be played and then the unit will pause. Set the tape to the beginning of side B, then press **■** or **▶**. The selections for side B will be played.

#### To check your program

Press CHECK. The first selection in the program will be displayed.

Each time you press CHECK, the next selection in the program will be displayed. When CHECK is pressed after the last selection, "END" appears and then the display returns the initial display.

#### To change your program

You can make the following changes before starting play.

#### To erase the last selection, press CLEAR.

Each time you press CLEAR, the last selection in the program will be erased.

To add a selection to the end of the program, just press the numeric button for that selection. You can add a selection also during play or pause.

To delete a selection, press CHECK repeatedly until the undesired selection is displayed. Then press CLEAR.

To change the order, press **■** during stop to erase the program. Then repeat the programming procedure from the beginning.

#### To adjust the blank spaces between selections

In a program, if you do not change the order of selections, the spaces between those selections remain the same as on the disc. Otherwise, the spaces are shortened to 1 second. You can make all the blank spaces 3 seconds long. See page 54 for details.

#### If "----" is displayed instead of the actual time

- You have programmed a selection number over 25.
- the total time has exceeded 100 minutes.

#### To check the remaining time

Press TIME/MEMO once to see the remaining time of the selection being played; twice to see the total remaining time; once more to return to the initial display.

If you have inserted a pause, the display shows the remaining number of selections and time until the pause.

If you have programmed a selection number over 25, "-----" is displayed instead of the actual time.

## Designating the Playing Order of Up To 6 Discs - Multi-disc Program

You can make a program by designation up to 24 selections from up to 6 discs in the order you want them to be played.

At the same time, you can adjust the total playing time of the program. This function is convenient for editing tapes.

#### To play the program

Insert the first disc and press **▶**.

When "NEXT DISC" is displayed, replace with the next disc and press **▶**. Continue replacing until the last disc. When playback of the last disc is completed, "END" will be displayed. The unit will return to the initial standby condition of program play from the first disc.

#### To stop playing

Press **■**.

#### To program while checking the total time

Use the **◀▶** and **▶▶** buttons instead of the numeric buttons to choose the desired selections. Choose a selection with the **◀▶** and **▶▶** buttons, check the total time, and then press MULTI PGM while the selection number is flashing.

#### To check your program

Press CHECK. Each time you press CHECK, the selection in the program will be displayed along with its selection number, order and disc number.

When CHECK is pressed after the last selection, "END" appears and then the display returns to the initial display.

#### To cancel multi-disc program

Press CONTINUE and return to the continuous playing mode. The program will be erased.

#### To change your program

You can make the following changes before starting play.

#### To erase the last selection

Insert the last disc programmed, and press CLEAR. Each time you press CLEAR, the last selection in the program will be erased. To continue erasing selections, replace the discs accordingly and repeat the procedure.

#### To add a selection to the end of the program

Insert a disc and press the numeric buttons for that selection. You can add a selection during stop.

#### To erase the entire program

Press **■** once during stop; twice during play. The program will be erased.

#### To check the current disc number

Press TIME/MEMO during stop. The disc number will be displayed.

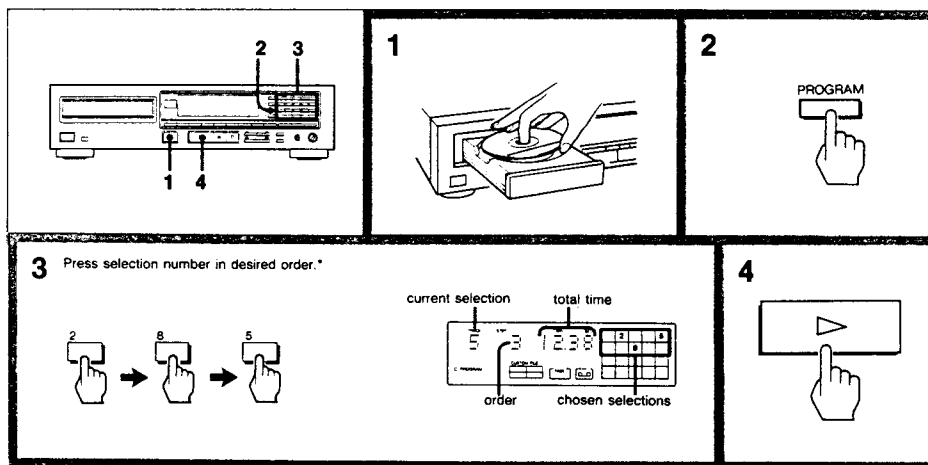

**If you mistake the disc order**

Even if a disc is inserted in an incorrect order, the selections chosen from that disc will be played. However, when a disc which has already been played is inserted, program play will not proceed. In addition, when a seventh disc is incorrectly inserted, "DISC FULL" will be displayed.

**The following functions cannot be conducted on Multi-disc programs.**

- Pause program
- Repeat play
- Time edit
- Time fade
- Program bank
- The tape side (A, B) can not be displayed.

## Designating the Playing Order and Time - Program Edit

You can make a program by designating up to 24 selections in the order you want them to be played. At the same time, you can adjust the total playing time of the program. The unit will play the disc according to your program. This function is convenient for editing tapes.

**To make a program for editing a tape**

You can insert a pause in your program. Use this function to make a program for both sides of the tape at one time. See page 34 for details.

**To check or change your program**

See page 36.

**To adjust the blank spaces between selections**

In a program, if you do not change the order of selections, the spaces between those selections remain the same as on the disc. Otherwise, the spaces are shortened to 1 second. You can make all the blank spaces 3 seconds long. See page 54 for details.

**To play the program**

Press ►.

**To stop playing**

Press ■.

You can play the same program repeatedly as long as you do not cancel program edit or erase the program.

**To cancel program edit**

Press CONTINUE and return to the continuous playing mode.

The program will be erased.

**To erase the entire program**

Press ■ once during stop; twice during play.

The program is also erased, when you turn off the unit.

**1** Insert disc.

**2** Press **MULT PGM**.

**3** Press selection number in desired order. Selections will be programmed in the selected order.

order ——— total time  
current selection ——— chosen selection

**3** Choose selection and check the time.

AMS ——— current selection ——— total time  
order ——— chosen selections

**4** If satisfactory, go to next step. If not, repeat step 3 and choose another selection.

**5** Store selection.

**6** Repeat steps 3 to 5.

## Designating the Total Playing Time - Time Edit



You can designate a time and the unit will make 2 different programs of selections each fitting within that period. Use this function, by designating the length of your tape, for editing both sides of a tape.

\* Press **10** for "0".  
You need not press keys for seconds, unless required.

### If your tape is of a standard length

You can designate the tape length easily with the TIME SET button.

Press TIME SET in step 3 above. Each time you press TIME SET, the display changes to give you the following duration:

23.00(C-46) → 27.00(C-54) → 30.00(C-60) → 45.00(C-90)

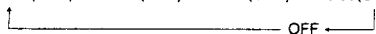

### If any selections remain unprogrammed

To make a further program, repeat step 5.

### To designate a different time for each side

Execute steps 1 to 4 and press **11**. Then repeat steps 2 and 4. Do not execute step 5.

### To play the program

Press **▶**.  
The selections for side A will be played and then the unit will pause. "B" lights up in the tape side indicator. Set the tape to the beginning of side B, then press **11** or **▶**.  
The selections for side B will be played.

### To stop playing

Press **■**.  
You can play the same program repeatedly as long as you do not cancel time edit or erase the program.

### To cancel time edit

Press CONTINUE and return to the continuous playing mode.  
The program will be erased.

### To erase the entire program

Press **■** once during stop; twice during play.  
The program is also erased, when you turn off the unit.

### To include desired selections in the program

- 1 Make your own program of the desired selections.  
See page 34 for instructions.
- 2 Follow the procedure as shown on the preceding page.  
Just designate the length of your tape; you need not subtract the length of your program. The unit will place your selections at the beginning of its program and add other selections to fit the remaining time.

### To check the program

See page 36.

### If your disc has more than 25 selections

Selections over 25 cannot be programmed with the time edit function; program desired selections before using the time edit function. See page 34 for details.

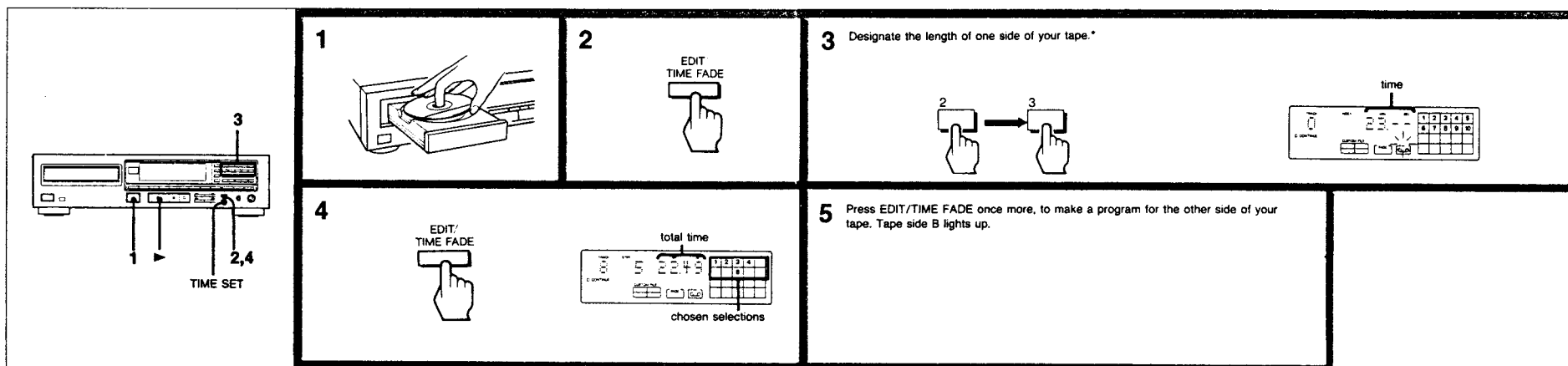

## Tips on Editing Tapes

The following functions are convenient for editing your own tapes. Time Fade and Fade in/Fade out cannot be operated when the DIGITAL (optical) OUT is used for connections.

### Fading Out at the Desired Time - Time Fade

You can have the play fade out at the end by designating the play duration. Once time fade is set, it functions twice for editing both sides of a tape. You can change discs without cancelling this function. The fade time is preset to 5 seconds, but you can change it between 2-10 seconds. This function cannot be conducted on multi-disc program.

#### To set the fade time

- 1 Press **II**.
- 2 Press FADER.
- 3 Press **◀/▶** to select fade time between 2-10 seconds.

#### To set time fade

- 1 Press EDIT/TIME FADE twice during stop. "TIME FADE" is displayed in the window.
- 2 Set the desired play duration, using numeric buttons.

e.g. To set to 27 minutes, press **2** **7** **10** **10**.  
You need not press buttons for seconds, unless required.

- 3 To start play, press **▶**.  
After the designated time, play fades out and pauses. Tape side B lights up. Press **II** or **▶** to resume playing for the other side of the tape. When the play fades out for the second time, the unit pauses and the time fade function is cancelled.

#### If your tape is of a standard length

You can designate the tape length easily with the TIME SET button. Press TIME SET in step 2 above. Each time you press TIME SET the display changes to give you the following duration:

23.00(C-46) — 27.00(C-54) — 30.00(C-60) — 45.00(C-90)  
OFF

#### If you want to start the play fading in

- 1 Press **II**.  
The unit enters the pause mode.
- 2 Press EDIT/TIME FADE once.  
"TIME FADE" is displayed.
- 3 Set the desired play duration, following step 2 on the page before.
- 4 To start play, press FADER.  
Play will start fading in and end at the set time fading out.

#### To cancel time fade

Time fade will be cancelled when  
- EDIT/TIME FADE is pressed once again.  
- **◀/▶** is pressed during play.

To display the time remaining until the time set  
Press TIME/MEMO twice.

### Fading in/Fading out

You can have the play fade in and fade out between 2-10 seconds. To set the fade time, see page 50. When no time is specified, the play will fade in and fade out for 5 seconds.

#### To end the play fading out

Press FADER when you want to start fading out. "FADE **II**" flashes in the window, and play fades out and unit enters the pause mode.

#### To restart the play fading in

Press FADER in the pause mode. "FADE **II**" flashes in the window, and play fades in.

### Inserting a Blank Space between Selections - Auto Space

You can insert a 3 seconds blank space between each selection. The blank space enables you to locate selections when using a tape deck with the automatic selection search function.

Before starting play, press AUTO SPACE so that "AUTO SPACE" is displayed in the window. A blank space of approximately 3 seconds will be inserted between each selection.

#### To cancel the auto space function

Press AUTO SPACE so that "SPACE OFF" is displayed in the window.

### Locating the loudest portion of the disc - Peak Search

The unit will scan a disc from beginning to end and determine the loudest portion (peak level) of the disc, and then play that portion repeatedly. This function will make it easier for you to adjust to the optimum level when recording on tape. You can use this function in the continuous, delete shuffle and program play modes.

#### To set peak search

Press PEAK SEARCH in the stop mode. "PEAK" flashes in the window. The entire tracks in a disc or program will be searched automatically. The loudest portion will be played repeatedly for 4 seconds.

#### To start play immediately

Press **▶**.

#### To stop peak search

Press **II**.  
Press **II** to pause at the first selection.

#### Note on peak search function

The unit determines the loudest portion (peak level) of a disc by searching it at fixed intervals. As a result, the portion searched may differ from the actual peak level. In addition, this function may determine different portions as the peak level for the same disc. However, the difference between the portion searched and the actual peak level is insignificant and will not present any problem in adjusting the recording level.

## On Custom Files

The CD player incorporates a memory in which you can store four types of information called "custom files".

### Four custom files you can store in memory

<b>Program bank</b>	A programmed playing order you store in memory for a disc, so that the disc can be played always in a fixed order. (page 60)
<b>Disc memo</b>	You can assign a title within 10 letters to each individual disc. (page 62)
<b>Custom index</b>	You can assign up to 10 index points on anywhere you want on a disc. (page 66)
<b>Level file</b>	You can assign a playback level to each individual disc, so that the disc can be played automatically on a fixed playback level. (page 70)

#### What is this indication?

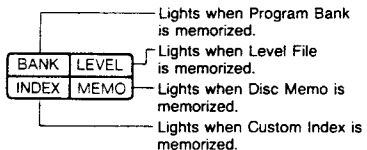

#### What is this indication?

This indication appears when FILE is pressed while no custom file can be memorized for the disc currently put in the player. To make a custom file for the disc, clear the custom file of another disc.

#### How many discs can be assigned custom files?

You can give custom files to up to 185 discs.

But it takes two discs' memory in the following case:

- When disc memo, custom index and program bank are memorized in one disc at the same time.
- When more than 9 custom indexes and disc memo are memorized at the same time.
- When custom index and program bank are memorized at the same time.

#### Where are custom files memorized?

Custom files are memorized not in the disc but in the player's memory. So you can't enjoy custom files with the other players without memorized custom files again. Custom files are retained for approximately 1 month without AC power supply.

#### Custom File Last Mode Memory

The last play mode (current play mode, repeat, auto space and fade time) of a disc containing custom files will be retained in the unit's memory when the disc is removed from the unit. When the disc is inserted again, the last play mode will be recalled. However, if you press the ► button while the disc table is open, the current play mode will take priority over the last play mode memorized.

#### To clear all custom files of a disc at once

You can use this function on a disc you have assigned a disc memo.

Press FILE RECALL repeatedly without the disc in the player, so that the desired disc memo is displayed. Then press ERASE. "FILE ERASE" appears and all custom files for that disc are erased.

#### To clear custom files or to reset memory of all discs at once

Press POWER to turn on the player while keeping ERASE and FILE pressed. "ALL ERASE" is displayed.

#### To check the items of the custom files

Press FILE RECALL (while "- NO DISC -" is displayed) without the disc inserted. Each time you press FILE RECALL, the items of the custom files and items of the each column of  about the disc are displayed. If you press FILE RECALL when the last disc's information is displayed, END is displayed and returns to "- NO DISC -" after a few seconds.

## Keeping the Program in Memory - Program Bank

### Memorizing Program

After programming selections, you can keep the program memorized, so that the disc is played always in the fixed order. The memorized program is called "program bank". You can assign one program bank for one disc.

- 1 Program the selections as you want (page 34).
- 2 Press FILE.

When "BANK" lights, the program is memorized for the program bank.

#### To change the program bank

Program the selections again and press FILE.

#### Where is the program bank memorized?

The program bank is memorized in the compact disc player's memory. Therefore, if a disc for which you made a program bank is used with another compact disc player, play using the program bank is not possible.

#### When the disc is in the disc tray

- 1 Press FILE RECALL during stop. "PROGRAM" appears.
- 2 Press ►.

#### To play the selections in another program without clearing the program bank

Put the disc in the disc compartment, press PROGRAM to program the selections as you want, and press ►. The disc will be played in the newly programmed order. The memorized program bank won't be cleared. (Press FILE RECALL to check the program bank.)

#### To play a disc having a program bank in other modes

To play a disc having a program bank in other modes, put the disc in the disc tray, set the player in the desired play mode and press ►.

### Clearing the Program Bank

- 1 Put the disc whose program bank is to be cleared in the player.
- 2 Press FILE RECALL.
- 3 Press ERASE.  
When "FILE ERASE" is displayed and "BANK" disappears the program bank is cleared.

### Playing the Disc Using the Program Bank

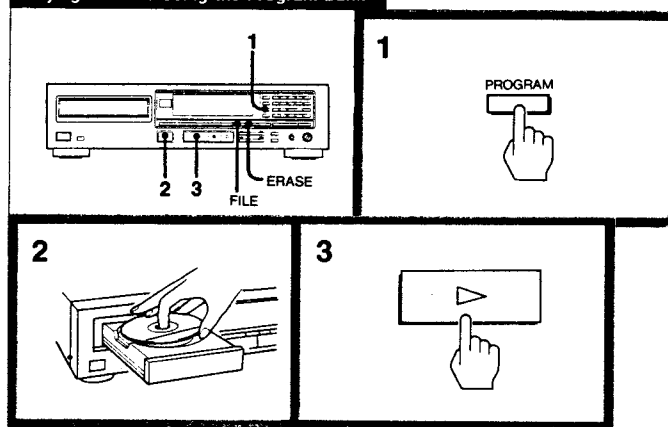

# Assigning names to a Disc

## - Disc Memo

Using the disc memo function, you can assign a name within 10 letters for each disc. The memo appears in the window every time you put the disc in the player. One name can be assigned for one disc. "- NO DISC -" can be changed to a desired indication.

### Usable letters and symbols

For the disc memo, 45 letters and symbols and space can be used. When the ◀▶ button is pressed for the first time, the space appears. Each time ▶▶ is pressed, letters and symbols will appear in the following order.

(space) A B C D E F G H I J K L M N O P Q R S T U V W X Y Z  
& ! . < > \* / + 9 8 7 6 5 4 3 2 1 0 -

Use ◀◀ to call up a previous character.

### To rewrite letters or symbols

Before pressing FILE, move the cursor under the letter/symbol to be changed, and then select the desired letter/symbol using ◀▶.

After pressing FILE, repeat the step form 2.

### To erase the letter and make space,

locate the desired place with ◀◀▶▶ and press CLEAR.

### Where is the disc memo stored?

The disc memo is stored in the compact disc player's memory. When a disc is put in the player, the player identifies the disc by the total number of selections and the total playing time. If a disc memo has been made for that disc, the player retrieves the memo from its memory and displays it in the window. Therefore, as the disc memo is not located on the disc itself, when the disc is put in another compact disc player, no memo will be displayed.

### What is this indication?

 This indication appears when you put the disc whose disc memo has already been memorized.





### If you press TIME/MEMO during stop

Each time you press TIME/MEMO, the memorized memo appears and disappears.

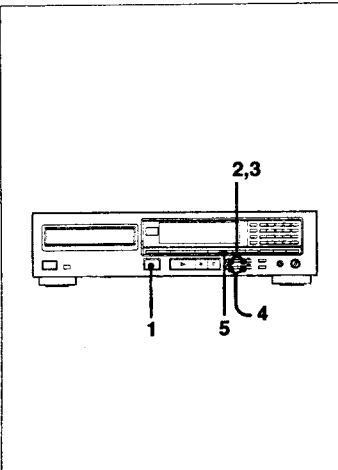
### To display the playing time of the disc whose memo has already been memorized

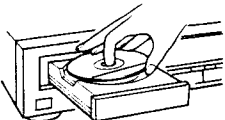

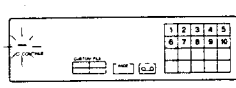
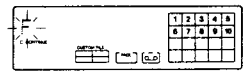
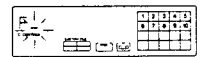
When the total remaining time of the disc is displayed, if you press TIME/MEMO, memo will be displayed.

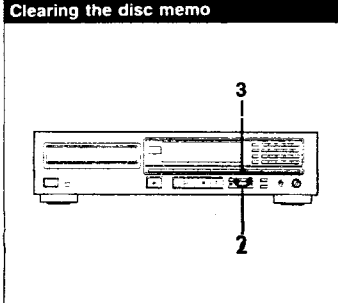

-  
- A blinking cursor (indicating where a letter will be written) appears.  
- Press ◀◀ or ▶▶ until the desired letter appears.  Example: If ▶▶ is pressed 7 times.
- Press ▶▶ to move the cursor to the next position, and select the desired letter. Repeat steps 3 and 4 to complete the memo. 
- "FILE" appears in the window. After about 1 second, the memo you have written will be displayed. Each time the disc is put in the compact disc player, the memo will be displayed. 

### Clearing the disc memo

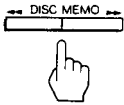

- Put the disc whose memo you want to clear in the player, and memo will be displayed.
-  The cursor blinks.
-  "FILE ERASE" is displayed in the window.

## Giving a Disc Indexes as You Want - Custom Index

A custom index is a special index that can be assigned to any position you want on the disc. If you assign custom indexes to the positions on a disc, you can easily locate the positions during play, or enjoy repeat play between two adjacent custom indexes.

### If you press FILE in the pause mode

The rehearsal play is not made and the custom index is assigned immediately at the position where FILE is pressed.

### To release rehearsal play

Press CLEAR. Normal play is resumed.

### If a new custom index is assigned to a position preceding another index

Previously existing indexes will be shifted as follows. Example: If you assign a new index between 2 and 3.

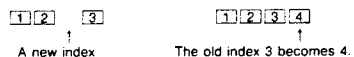

### What is this indication?



This indication appears when custom index has already been memorized for the disc.

### During custom index mode

You cannot use the normal index search, however, search of custom index function is possible.

## Playing from Desired Custom Index

### To play from an index to the end of the disc

- 1 Press C.INDEX.
- 2 Select the desired custom index by pressing the desired numeric button 1 through 10.

### To play from one index to the next

- 1 Press C.INDEX twice so that "C.INDEX (SINGLE)" is displayed.
- 2 Select the desired custom index by pressing the desired numeric button 1 through 10.

### To play repeatedly between adjacent indexes

Press REPEAT between step 1 and step 2 above. To cancel repeat play, press REPEAT again.

### To access an index during play

- 1 Press C.INDEX.
- 2 Press  $\leftarrow/\rightarrow$  on the remote commander.
  - $\rightarrow$ : Accesses the next index.
  - $\leftarrow$ : Returns to the preceding index.
 (To go further back, use the numeric buttons.)

### To change the play mode during play using custom indexes

During play using custom indexes (in other words, while the music calendar is not displayed), the play mode switches from continuous play to single play and vice versa each time C.INDEX is pressed.

### To release play using custom indexes

Press one of the PLAY MODE buttons (PROGRAM, SHUFFLE or CONTINUE). The music calendar appears.

## Clearing Custom Indexes

- 1 Press C.INDEX. C.INDEX appears.
- 2 Press CHECK. Each time you press CHECK, index number blinks. Select the index number you want to delete.
- 3 Press ERASE while index number blinks. The specified index will be erased and the succeeding index numbers will move up one.

**1** Press C.INDEX during play.

**2** Press FILE where you want to assign a custom index. The portion for 3 seconds from the point where you pressed FILE is played repeatedly (rehearsal play).

**3** Adjust the repeat start point using  $\leftarrow\leftarrow$  or  $\rightarrow\rightarrow$ .

Press  $\rightarrow\rightarrow$  to shift the repeat start point forward and  $\leftarrow\leftarrow$  to shift it backward. Pressing  $\leftarrow\rightarrow\rightarrow$  7 times shift the point by approximately 1 second.

**4** Press FILE to keep the custom index in memory.

The custom index is assigned to the repeat start point.

**5** You can assign custom indexes up to 10 positions by repeating steps from 2 to 4.



## Storing an Optimum Playback Level for Each Disc - Level File

You can have the unit memorize an optimum playback level for each individual disc. Each time you play a disc, the volume will be set to the level memorized for that disc.

This function can be used when the amplifier is connected to the VARIABLE LINE OUT terminals or when headphones are used.

### To play the disc using the level file

Each time the disc is inserted into the player, the LINE OUT/PHONE LEVEL control will automatically turn to the designated playback level.

### To clear level file

- 1 Insert a disc in the compartment.
- 2 Press LEVEL FILE.
- 3 Press ERASE.

### When the playback level is changed

Press FILE RECALL during stop. The LINE OUT/PHONE LEVEL control will automatically be reset to the memorized playback level.

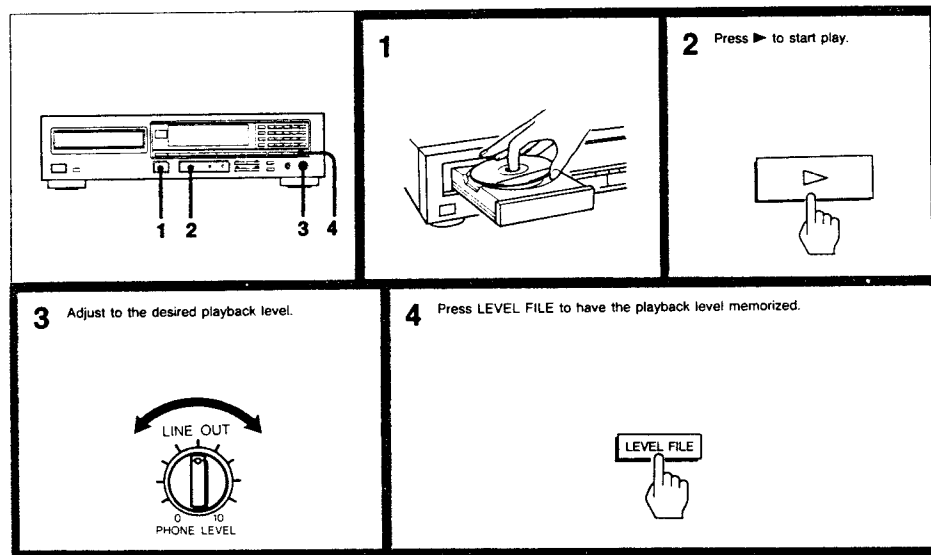

## Timer Activated Playing

By connecting a commercially available timer, disc play of the desired play mode can be started at any desired time.

- 1 Insert a disc in the compartment.
- 2 Select the desired play mode.
- 3 Set the timer.
- 4 Set TIMER to PLAY.

### Keep the POWER switch depressed on the player

When the timer is set, the power of the player will be cut off.

However, be sure to leave the POWER switch on.

### When the timer-activated play ends

Be sure to set TIMER to OFF. If the TIMER switch is left at PLAY, the unit will automatically start playing the next time the power is turned on.

### To play in the program play mode

Make a program bank (page 60) and then prepare for timer activated playing.

### If you select the custom index play mode

Play begins from custom index 1.

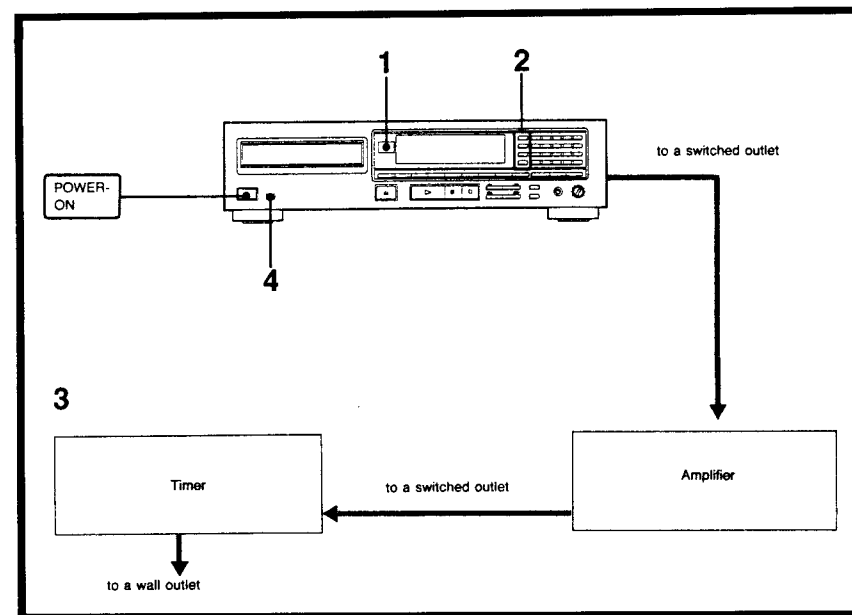

## SECTION 2 DISASSEMBLY

### 2-1. Removal of LOADING PANEL

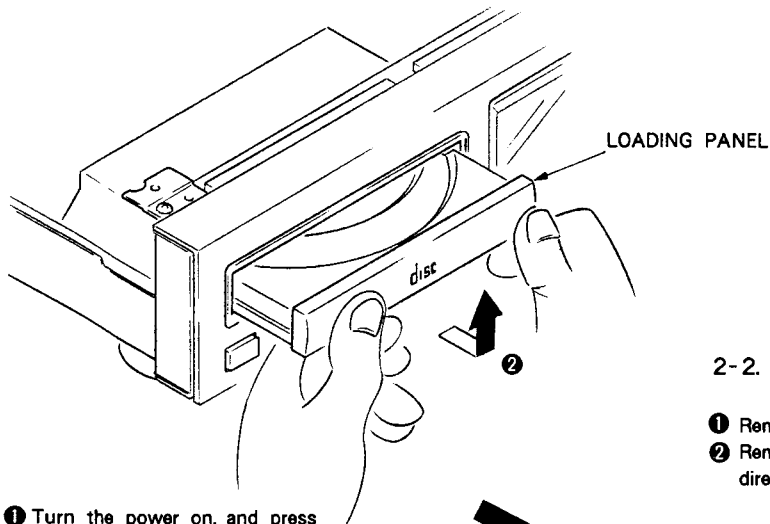

- ① Turn the power on, and press  $\blacktriangle$  (OPEN/CLOSE) button to open DISC TABLE.
- ② Push LOADING PANEL up with twisting it as shown by arrow ②.

### 2-2. Removal of CD MECHANISM BLOCK (CDM11C-5H)

- ① Remove 4 screws.
- ② Remove CDM11C-5H in the direction of arrow.

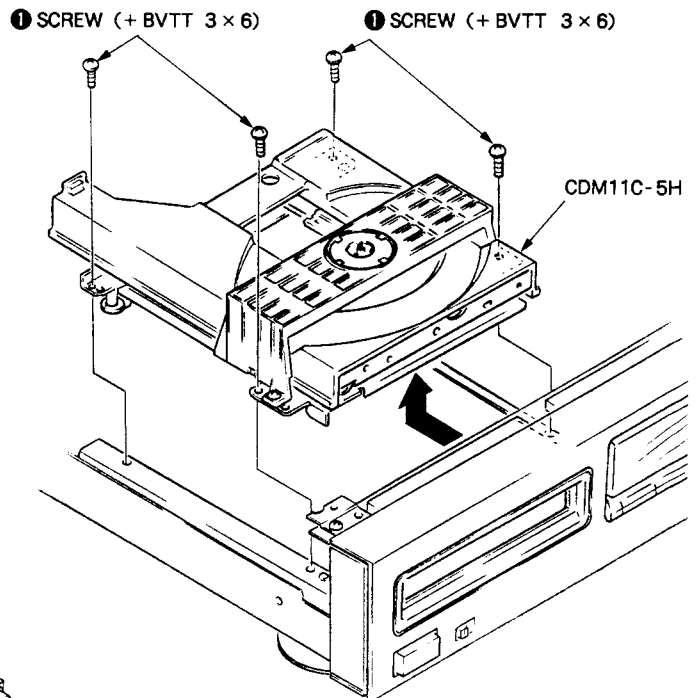

### 2-3. Removal of BASE UNIT (BU-5H)

- ① Remove LIMITER.
- ② Remove YOKE BRACKET.
- ③ Remove GND LUG.
- ④ Release claw and remove BU-5H in the direction of arrow.

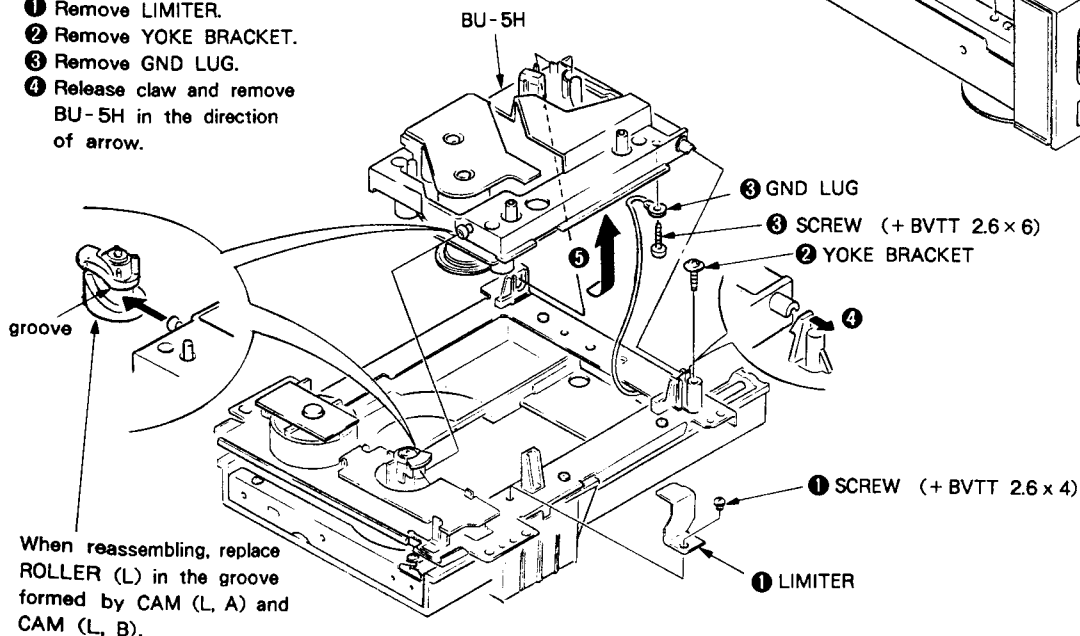

2-4. Removal of MOTOR ASSY

- ① Remove 4 screws.
- ① SCREW (+ BTP 2.6 × 8)

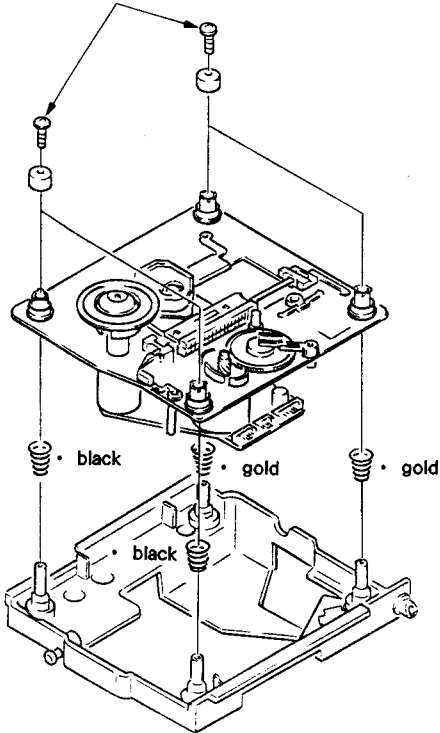

Note: When reassembling, be careful not to mistake position of springs marked with •



2-5. Removal of OPTICAL PICK-UP BLOCK (KSS-240A)

- ① Push STOPPER away from the tip of SLED SHAFT.
- ② Slide out SLED SHAFT in the direction of arrow.
- ③ Remove OPTICAL PICK-UP BLOCK (KSS-240A) in the direction of arrow.
- ④ Disconnect FLAT CABLE from the connector.

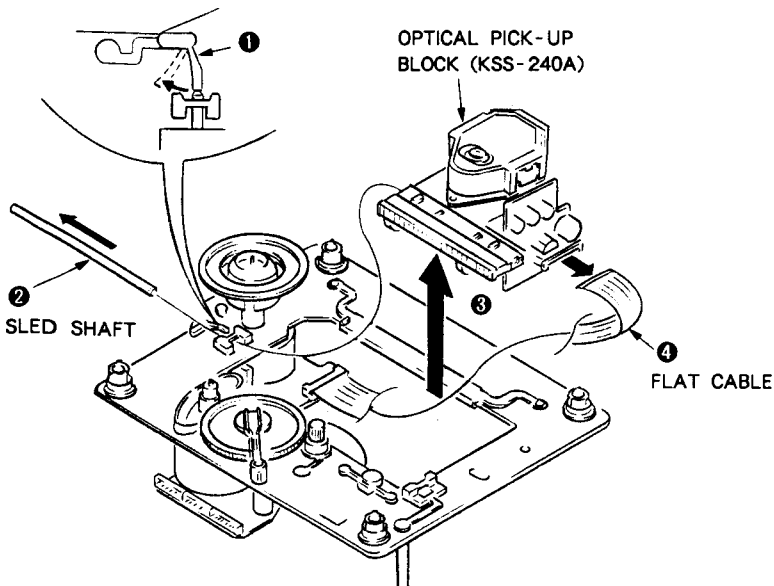

2-6. Removal of DISC TABLE and BELT

- ① Remove 2 screws.
- ② Remove HOLDER with releasing claws as shown by arrows ②.
- ③ Remove 2 screws.
- ④ Remove REINFORCEMENT, then DISC TABLE comes off.
- ⑤ Remove GEAR (P) and GEAR (C).
- ⑥ Remove BELT.

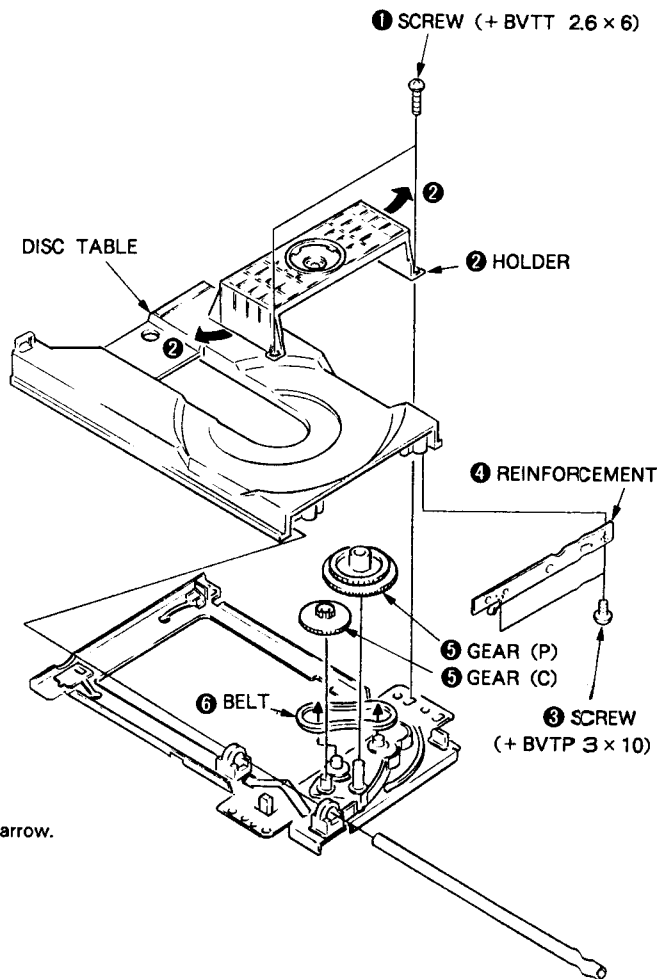

## SECTION 3 ELECTRICAL ADJUSTMENTS

### ELECTRICAL ADJUSTMENTS

1. Perform adjustments in the order given.
2. Use YEDS-18 (Part No: 3-702-101-01) disc unless otherwise indicated.
3. Use the oscilloscope with more than  $10^6 \text{M}\Omega$  impedance.

#### RF PLL Free Run Frequency Check

Procedure :

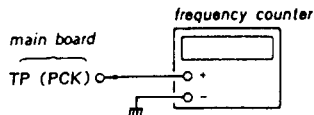

1. Put the set into test mode.
2. Connect the frequency counter to TP (PCK).
3. Turn the power on.
4. Set disc (YEDS-18) and press ▷PLAY button.
5. Confirm that the reading on frequency counter is 4.3218MHz.
6. Turn the power off.

#### E-F Balance Check

This check should be made after replacing the optical pick-up block.

Procedure :

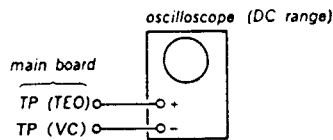

1. Put the set into test mode.
2. Connect TP (TES) to ground with lead wire.
3. Connect oscilloscope to TP (TEO).
4. Set disc (YEDS-18) and press ▷PLAY button.
5. Confirm that the traverse waveform is symmetrical about 0V-axis.
6. Turn power off and remove the lead wire connected to TP (TEO).

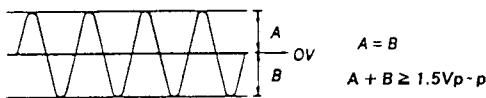

#### RF Level Check

This check should be made after replacing the optical pick-up block.

Procedure :

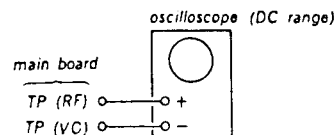

1. Put the set into test mode.
2. Connect oscilloscope to TP (RF) and TP (VC).
3. Set disc (YEDS-18) and press PLAY button.
4. Confirm that waveform eye pattern is clear and RF level is optimum. The optimum eye pattern means that shape "◇" can be clearly distinguished at the center of the waveform.
5. Turn the power off.

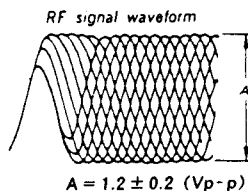

### REFERENCE

#### Focus/Tracking Gain Adjustments

A frequency response analyzer is necessary in order to perform this adjustment exactly.

However, this gain has a margin, so even if it is slightly off, there is no problem. Therefore, do not perform this adjustment.

Focus/tracking gain determines the pick-up follow up (vertical and horizontal) relative to mechanical noise and shock when the 2-axis device operate.

However, as these reciprocate, the adjustment is at the point where both are satisfied.

- When gain is raised, the noise when the 2-axis device operates increases.
- When gain is lowered, mechanical shock and skipping occurs more easily.
- When gain adjustment is off, the symptoms below appear.

Symptoms	Gain	Focus	Tracking
<ul style="list-style-type: none"> <li>• The time until music starts becomes longer for ■ STOP → ▷ PLAY or automatic selection. (◀◀, ▶▶ buttons pressed.) (Normally takes about 1 seconds.)</li> </ul>	-	low	low or high
<ul style="list-style-type: none"> <li>• Music does not start and disc continues to rotate for ■ STOP → ▷ PLAY or automatic selection. (◀◀, ▶▶ buttons pressed.)</li> </ul>	-	-	low
<ul style="list-style-type: none"> <li>• Sound is interrupted during PLAY or time counter display stops progressing.</li> </ul>	-	-	low
<ul style="list-style-type: none"> <li>• More noise during 2-axis device operation.</li> </ul>	high	high	high

The following is a simple adjustment method.

- Primary Adjustment -

**Note :** Since exact adjustment cannot be performed, remember the positions of the controls before performing the adjustment. If the position after the primary adjustment are only a little different, return the controls to the original position.

Procedure :

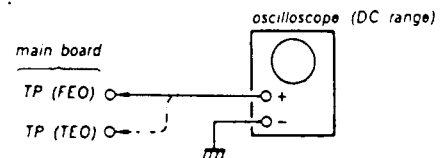

1. Keep the set horizontal.  
(If the set is not horizontal, this adjustment cannot be performed due to the gravity against the 2-axis device.)
2. Put the set into test mode.
3. Set disc (YEDS-18) and turn POWER switch on.
4. Connect oscilloscope to main amp board TP (FEO).
5. Adjust RV 202 so that the waveform is as shown in the figure below. (focus gain adjustment)

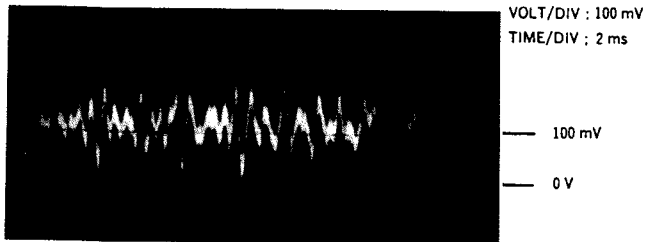

- Incorrect Examples (DC level changes more than on adjusted waveform)

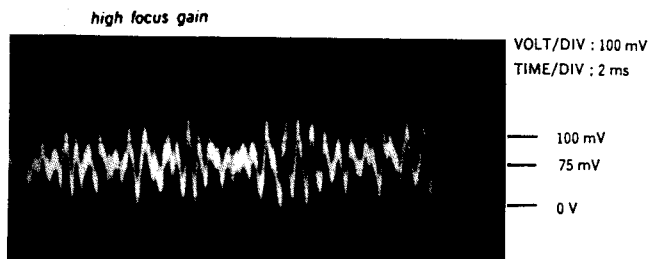
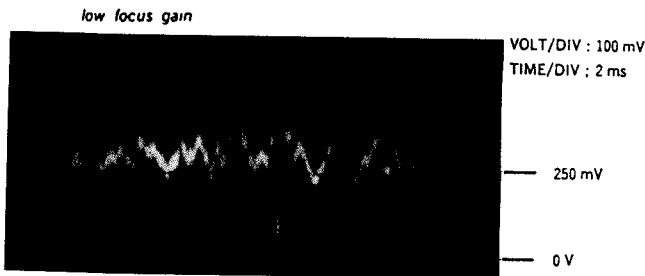

6. Connect oscilloscope to main board TP (TEO).
7. Adjust RV201 so that the waveform is as shown in the figure below. (tracking gain adjustment)
8. Turn POWER switch off.

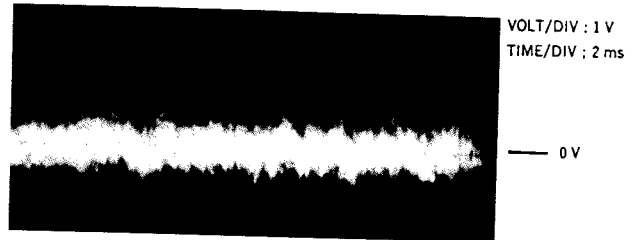

- Incorrect Examples (fundamental wave appears)

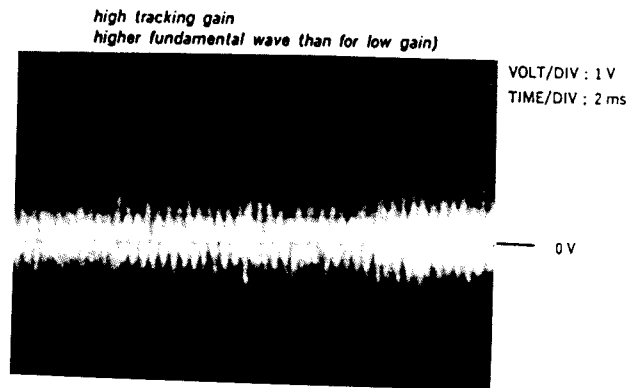
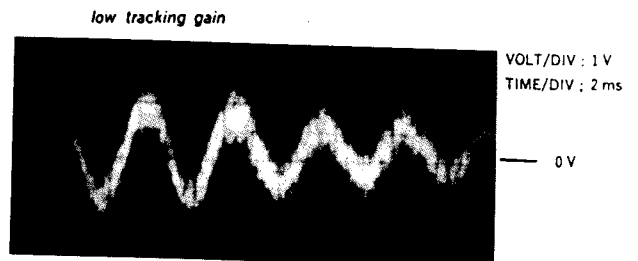

Adjustment point : MAIN Board (component side)

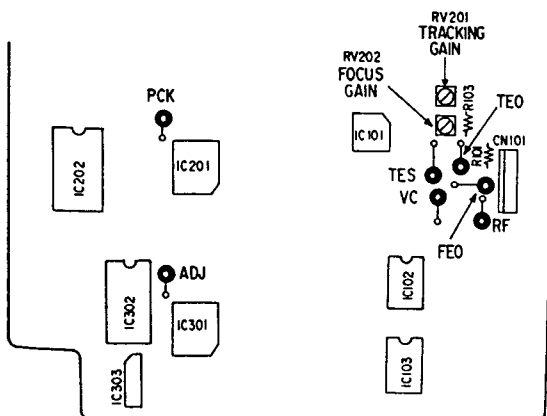

## SECTION 4 DIAGRAMS

### 4-1. CIRCUIT BOARDS LOCATION

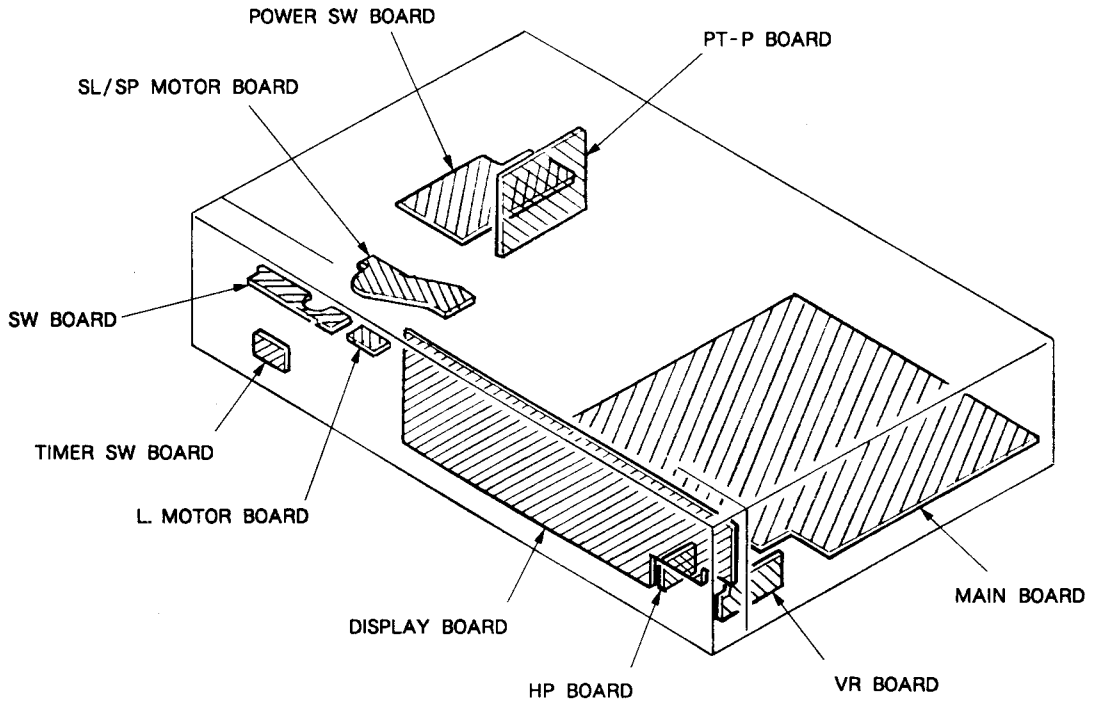

### 4-2. SEMICONDUCTOR LEAD LAYOUTS

CXA1291P

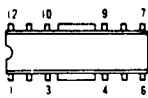

GP1F31T

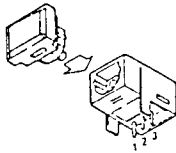

GP1U52 X B

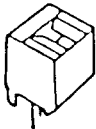

BN1L3ZK  
2SC2785-HFE

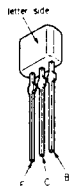

DTC114EF



DTC114ES  
DTC144ES  
DTA114ES



2SB1094-L  
2SD1913SA-RS

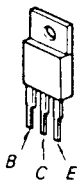

2SC2878B  
2SC3623AL



2SD774-34



2SK161GR



AA5534S

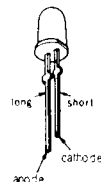

BG5535S

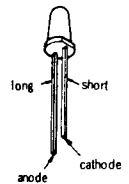

HZS36-3L  
HZS982L  
RD4.3ES-B2  
RD5.1JS-B1  
1SS202-1

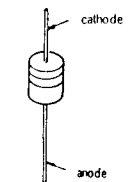

ERB83-004  
10E2N

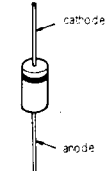

## 4-3. Description on IC101 (CXA1372Q)

Pin No.	Pin Name	I/O	Pin Description
1	VC		GND when two ( $\pm$ ) dual power supplies are in use, or the center voltage (2.5 V) when a single power supply is in use.
2	FGD	I	Time constants for gain switching in normal mode/down mode and for focus gain are connected between the FGD and FS3 pins.
3	FS3	I	
4	FLB	I	The capacitor for low frequency boost in the focus servo loop is connected.
5	FEO	O	Focus drive output
6	FE-	I	Inverted input to focus amplifier
7	SRCH	I	Time constants to generate the focus search waveform are connected.
8	TGU	I	Time constants for gain switching in normal mode/up mode and for tracking gain are connected between TGU pin and TG2 pin.
9	TG2	I	
10	AVCC		Analog power supply (5 V when $\pm$ dual power supplies are in use, 5 V when a single power supply is in use.)
11	TAO	O	Tracking drive output
12	TA-	I	Inverted input to tracking amplifier
13	SL+	I	Non-inverted input to sled amplifier
14	SLO	O	Sled drive output
15	SL-	I	Non-inverted input to sled amplifier
16	ESET	I	The 610-k $\Omega$ phase compensator resistor is connected to this pin.
17	ISET	I	The current setting resistor is connected to this pin.
18	SSTOP	I	The limit switch is connected to this pin.
19	AVEE		Analog power supply (-5V when $\pm$ dual power supplies are in use, or GND when a single power supply is in use.)
20	DIRC	I	Direct control pin.
21	LOCK	I	Sled run-away prevention circuit operates when this signal is "L".
22	CLK	I	Serial data transfer clock input that is supplied from CPU (or DSP).
23	XLT	I	Latch input from CPU (or DSP).
24	DATA	I	Serial data input from CPU (or DSP).
25	XRST	I	System reset. "L" to reset.
26	C.OUT	O	Output to tracking counter.
27	SENS	O	SENS output
28	DGND		Digital ground (GND). (GND when $\pm$ dual power supplies are in use. GND when a single power supply is in use.)
29	MIRR	O	Mirror output.
30	DFCT	O	Defect output. "H" when defective.
31	ASY	I	Auto-assymetry control input.
32	EFM	O	EFM comparator output.

Pin No.	Pin Name	I/O	Pin Description
33	FOK	O	Focus OK.
34	CC2	I	Defect-bottom-hold input (input by capacitive coupling).
35	CC1	O	Defect-bottom-hold output.
36	DVCC		Digital power supply (+5 V when $\pm$ dual power supplies in use. +5 V when a single power supply is in use.)
37	CB	I	The defect-bottom-hold capacitor is connected to this pin.
38	CP	I	The mirror hold capacitor is connected to this pin.
39	RF1	I	RF signal input (input by capacitive coupling).
40	RF0	I	RF signal input (input by DC coupling).
41	DVEE		Digital power supply (-5 V when $\pm$ dual power supplies are in use. GND when a single power supply is in use.)
42	TZC	I	Tracking zero cross comparator input.
43	TE	I	Tracking error input.
44	TDFCT	I	The defect prevention hold capacitor is connected to this pin.
45	ATSC	I	Anti-shock input.
46	FZC	I	Focus zero-cross comparator input.
47	FE	I	Focus error input.
48	FDFCT	I	The defect prevention hold capacitor is connected to this pin.



## 4-4. Description on IC801 (MSC62408-003GS-K)

Pin No.	Pin name	I/O	Description
1	SCAN 6	0	Key scan 6
2	TIMER SW	I	Timer Switch input
3	KEY 0	I	Key 0 input
4	KEY 1	I	Key 1 input
5	KEY 2	I	Key 2 input
6	KEY 3	I	Key 3 input
7	KEY 4	I	Key 4 input
8	KEY 5	I	Key 5 input
9	KEY 6	I	Key 6 input
10	CMD 0	I/O	Master micon interface 0
11	CMD 1	I/O	Master micon interface 1
12	CMD 2	I/O	Master micon interface 2
13	CMD 3	I/O	Master micon interface 3
14	MREQ	0	Master micom command request
15	SACK	I	Command acknowledge input
16	M/F	I/O	Master/File command select
17	RMIN	I	Remocon signal input
18	—	—	No connection
19	QINT	I	Cominication control
20	RESET	I	RESET input
21	—	—	GND
22	—	—	No connection
23	TEST	I	Check pin
24	C. I. LED	0	Play mode LED control (CUSTOM INDEX)
25	PRG. LED	0	Play mode LED control (PROGRAM)
26	SHF. LED	0	Play mode LED control (SHUFFLE)
27	CON. LED	0	Play mode LED control (CONTINUE)
28	PAU. LED	0	PAUSE button LED control
29	PLY. LED	0	PLAY button LED control
30	OSC1	—	Oscillator
31	OSC0	—	Oscillator
32	Vss	—	GND
33	DIGIT 12	0	FLD driver (digit)
34	DIGIT 11	0	FLD driver (digit)
35	DIGIT 10	0	FLD driver (digit)
36	DIGIT 9	0	FLD driver (digit)
37	DIGIT 8	0	FLD driver (digit)
38	DIGIT 7	0	FLD driver (digit)
39	DIGIT 6	0	FLD driver (digit)
40	DIGIT 5	0	FLD driver (digit)

Pin No.	Pin name	I/O	Description
41	DIGIT 4	0	FLD driver (digit)
42	DIGIT 3	0	FLD driver (digit)
43	DIGIT 2	0	FLD driver (digit)
44	DIGIT 1	0	FLD driver (digit)
45	SEG $\beta$	0	FLD driver (segment)
46	SEG $\alpha$	0	FLD driver (segment)
47	SEG z	0	FLD driver (segment)
48	SEG y	0	FLD driver (segment)
49	VFLT	—	+30V
50	SEG x	0	FLD driver (segment)
51	SEG w	0	FLD driver (segment)
52	SEG v	0	FLD driver (segment)
53	SEG u	0	FLD driver (segment)
54	SEG t	0	FLD driver (segment)
55	SEG s	0	FLD driver (segment)
56	SEG r	0	FLD driver (segment)
57	SEG q	0	FLD driver (segment)
58	SEG p	0	FLD driver (segment)
59	SEG o	0	FLD driver (segment)
60	SEG n	0	FLD driver (segment)
61	SEG m	0	FLD driver (segment)
62	SEG l	0	FLD driver (segment)
63	SEG k	0	FLD driver (segment)
64	SEG j	0	FLD driver (segment)
65	SEG i	0	FLD driver (segment)
66	SEG h	0	FLD driver (segment)
67	SEG g	0	FLD driver (segment)
68	SEG f	0	FLD driver (segment)
69	SEG e	0	FLD driver (segment)
70	SEG d	0	FLD driver (segment)
71	SEG c	0	FLD driver (segment)
72	SEG b	0	FLD driver (segment)
73	SEG a	0	FLD driver (segment)
74	Vcc	—	+5V
75	SCAN 0	0	Key scan 0
76	SCAN 1	0	Key scan 1
77	SCAN 2	0	Key scan 2
78	SCAN 3	0	Key scan 3
79	SCAN 4	0	Key scan 4
80	SCAN 5	0	Key scan 5

## 4-5. Description on IC301 (M37450M8-130FP)

Pin No.	Pin name	I/O	Description
1	—	—	No connection
2	DIRCON	0	SSP direct control
3	MIRR	I	MIRR count input
4	QINT	0	Command output pulse
5	M/F	I/O	Master/File command select
6	SACK	0	Command acknowledge output
7	MREQ	I	Master micon command request
8	CMD3	I/O	Master micon interface 3
9	CMD2	I/O	Master micon interface 2
10	CMD1	I/O	Master micon interface 1
11	CMD0	I/O	Master micon interface 0
12	CLK	0	SSP, DSP data clock
13	XLT	0	SSP, DSP data latch pulse
14	DATA	0	SSP, DSP data
15	ATT	0	D/F (digital filter) attenuate data
16	SHIFT	0	D/F serial data clock
17	LATCH	0	D/F data latch pulse
18	LDON	0	Laser on/off (Laser on "H")
19	SCOR	I	SUB-Q sync input
20	—	—	No connection
21	—	—	No connection
22	—	—	No connection
23	—	—	No connection
24	—	—	No connection
25	—	—	GND
26	RESET	I	RESET input
27	—	—	No connection
28	XIN	I	Clock oscillator
29	XOUT	0	Clock oscillator
30	—	—	No connection
31	—	—	No connection
32	Vss	—	GND
33	AMUTE	0	Audio mute out(mute on "H")
34	MUTE	0	Digital mute out(mute on "H")
35	WE	0	64K-SRAM write enable
36	A12	0	64K-SRAM adress line A12
37	A11	0	64K-SRAM adress line A11
38	A10	0	64K-SRAM adress line A10
39	A9	0	64K-SRAM adress line A9
40	A8	0	64K-SRAM adress line A8

Pin No.	Pin name	I/O	Description
41	—	—	No connection
42	A7	0	64K-SRAM adress line A7
43	A6	0	64K-SRAM adress line A6
44	A5	0	64K-SRAM adress line A5
45	A4	0	64K-SRAM adress line A4
46	A3	0	64K-SRAM adress line A3
47	A2	0	64K-SRAM adress line A2
48	A1	0	64K-SRAM adress line A1
49	A0	0	64K-SRAM adress line A0
50	D7	I/O	64K-SRAM data line D7
51	D6	I/O	64K-SRAM data line D6
52	D5	I/O	64K-SRAM data line D5
53	D4	I/O	64K-SRAM data line D4
54	D3	I/O	64K-SRAM data line D3
55	D2	I/O	64K-SRAM data line D2
56	D1	I/O	64K-SRAM data line D1
57	D0	I/O	64K-SRAM data line D0
58	SENSE	I	SSP, DSP sense terminal
59	GFS	I	GFS input
60	FOK	I	FOK input
61	ADJ	I	ADJ mode terminal
62	AFADJ	I	AFADJ mode terminal
63	INSW	I	Loading in switch
64	OUTSW	I	Loading out switch
65	VLEVEL	I	Line out volume level input
66	VOLUP	0	Line out volume level up output
67	VOLDWN	0	Line out volume level down output
68	—	—	+5V
69	—	—	+5v
70	—	—	GND
71	—	—	+5V
72	Vcc	—	+5v
73	Vss	—	GND
74	DFCTSW	0	DEFECT circuit control terminal
75	SQCLK	0	SUB-Q read clock
76	VOLLED	0	Line volume LED control terminal
77	SUBQ	I	SUB-Q serial data
78	LODIN	0	Loading in output
79	LODOUT	0	Loading out output
80	—	—	No connection

4-6. BLOCK DIAGRAM

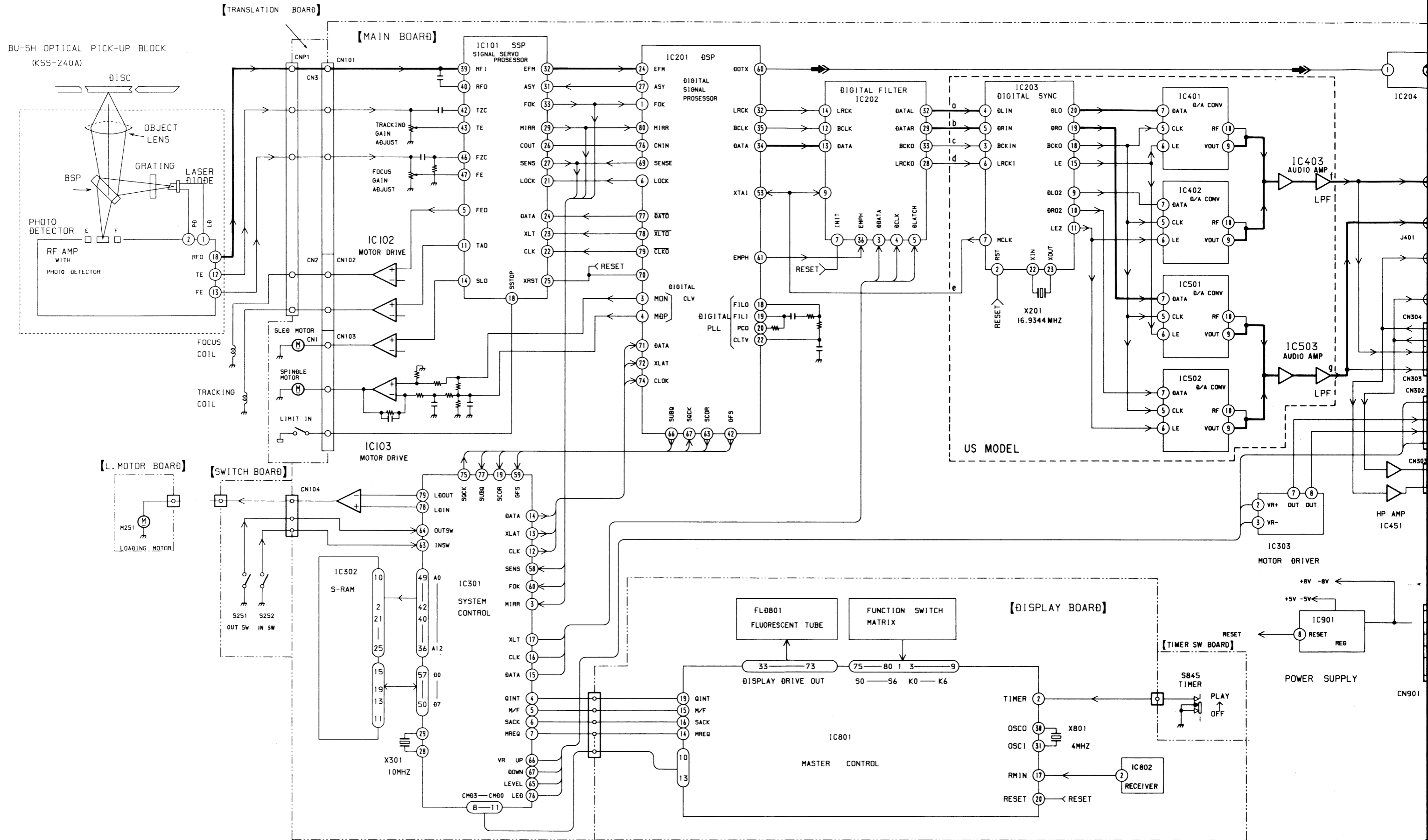

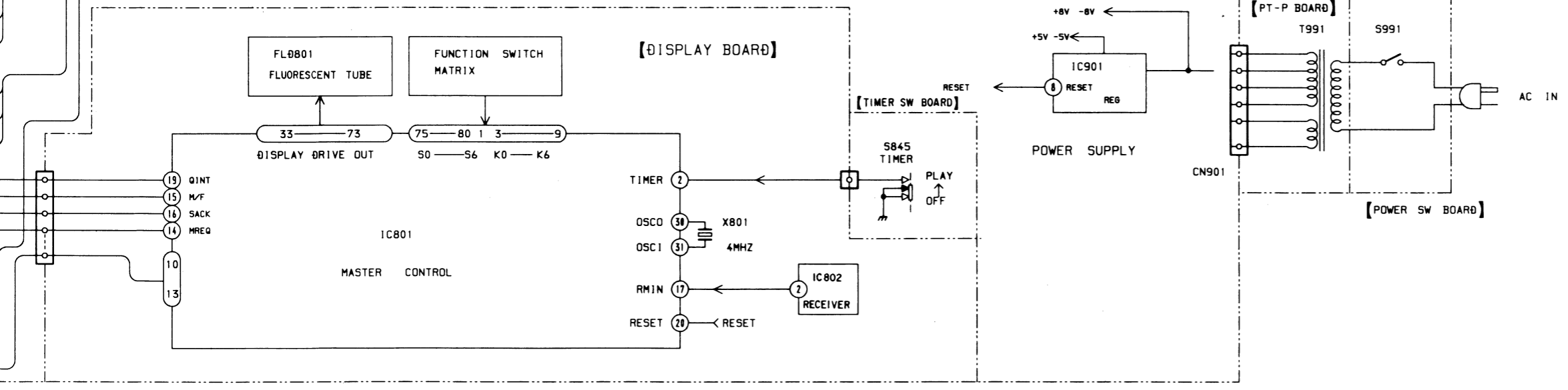
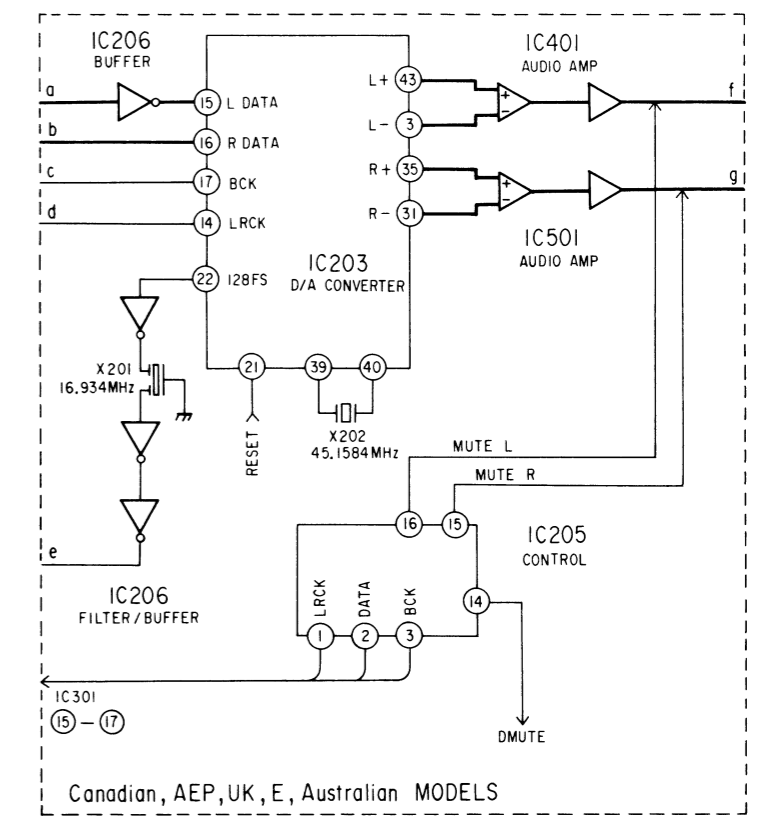
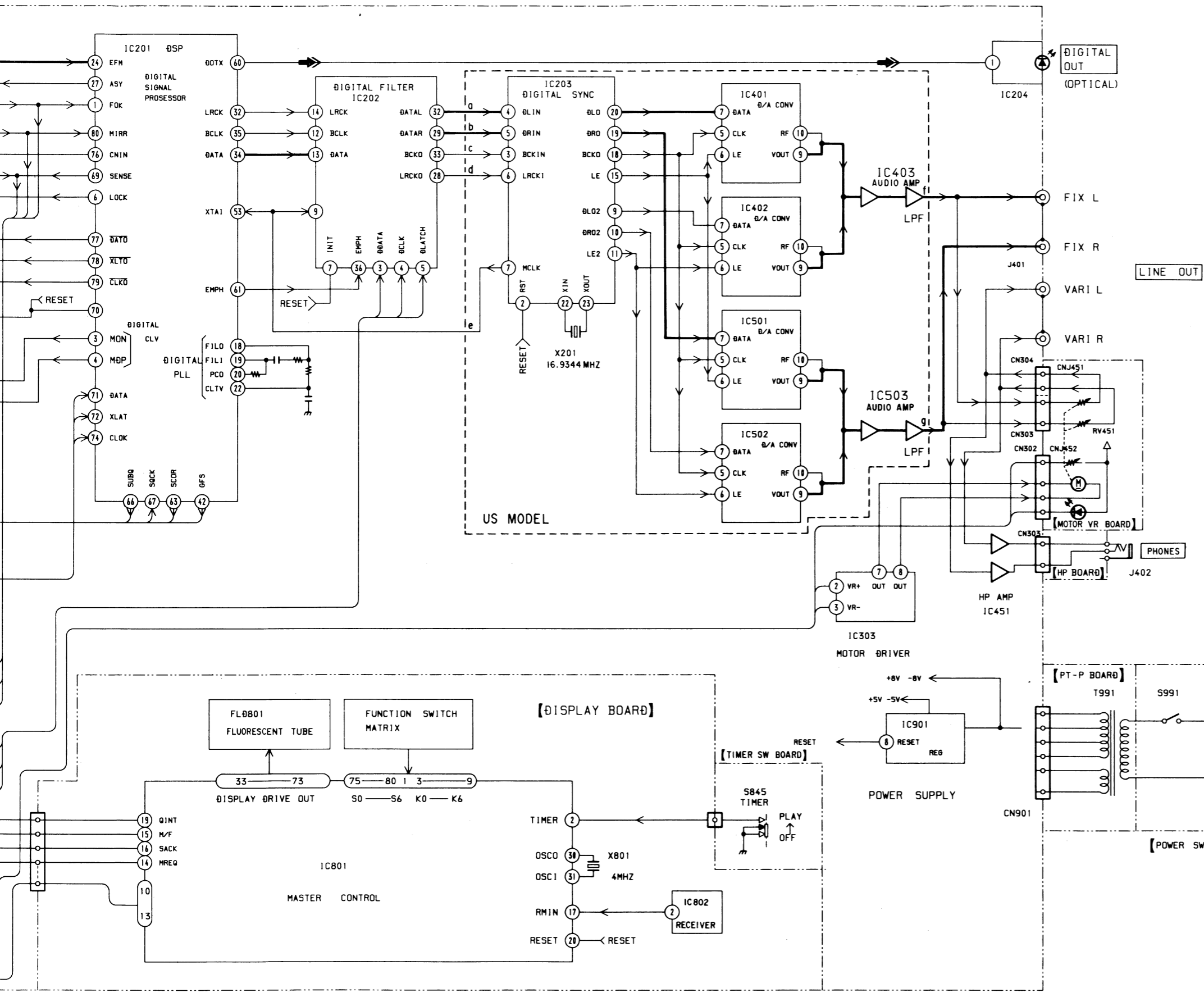

• Semiconductor Location

Ref. No.	Location
D351	F-18
D801	J-3
D802	J-3
D803	J-3
D804	J-3
D805	J-3
D806	J-3
D807	J-3
D808	I-4
D809	I-5
D901	C-19
D902	B-19
D903	B-19
D904	B-19
D906	E-19
D907	B-19
D908	D-19
D909	C-19
D910	D-19
D911	C-19
D912	C-19
D913	C-19
D914	C-19
D915	E-19
D916	E-18
IC101	G-18
IC102	I-18
IC103	K-18
IC201	H-15
IC202	H-13
IC203	F-14
IC204	A-14
IC301	J-15
IC302	J-14
IC303	K-14
IC401	E-14
IC402	E-13
IC403	D-13
IC451	E-17
IC501	E-15
IC502	E-15
IC503	D-15
IC801	J-4
IC802	J-1
IC901	B-17
Q101	I-18
Q301	K-16
Q351	F-19
Q352	F-19
Q401	C-13
Q402	C-13
Q501	C-15
Q502	C-15
Q801	J-5
Q802	J-5
Q803	J-6
Q804	K-6
Q901	C-18
Q902	B-18
Q903	D-19
Q904	E-19
Q905	E-18
Q906	E-18

Note on Mounting Diagram:

- — : parts extracted from the component side.
- ■ : parts mounted on the conductor side.

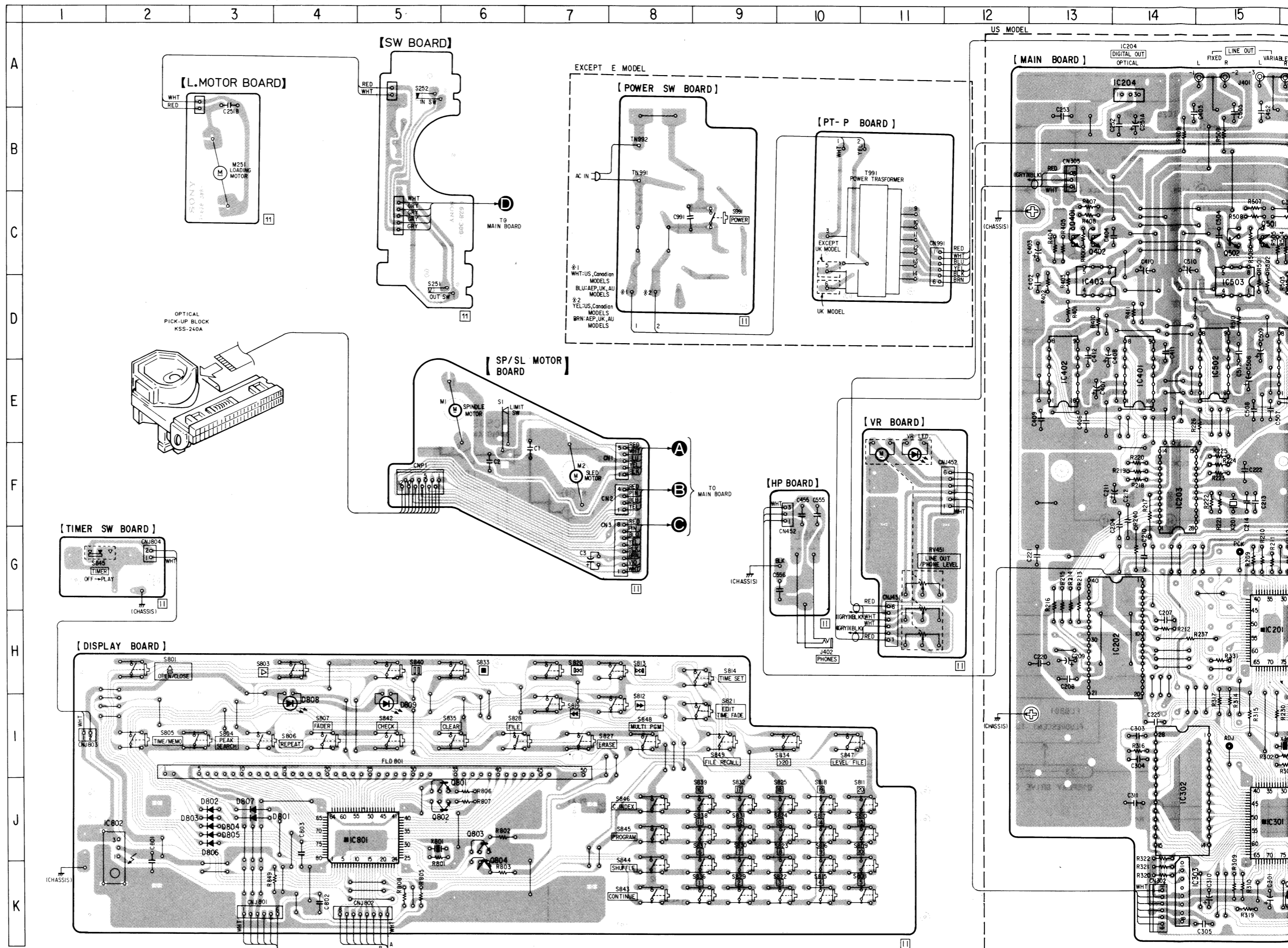

**[SW BOARD]**

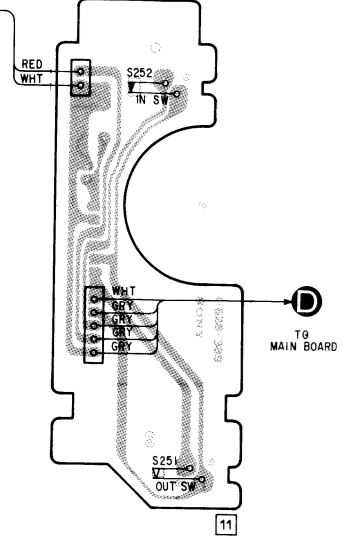

**[POWER SW BOARD]**

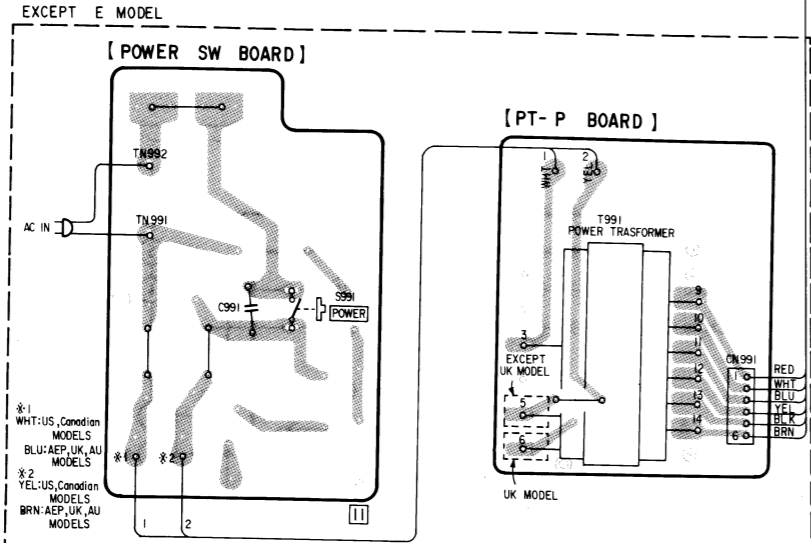

**[PT-P BOARD]**

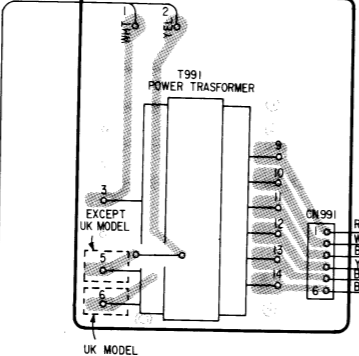

**[SP/SL MOTOR BOARD]**

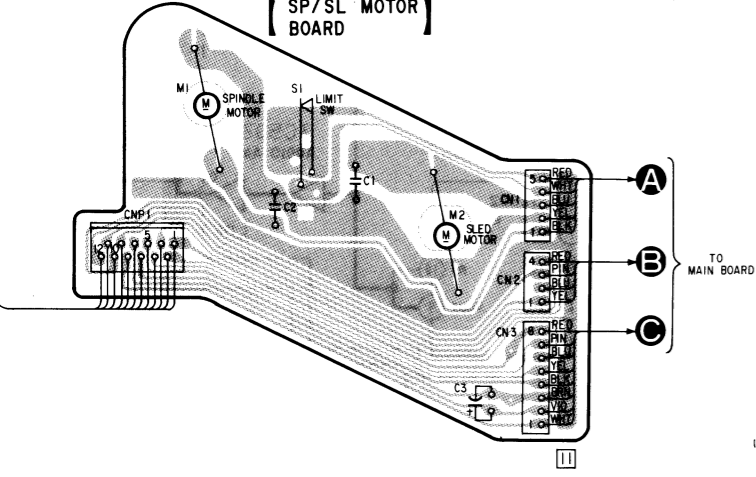

**[VR BOARD]**

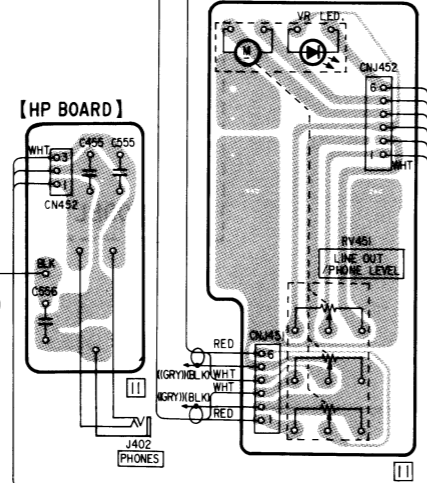

**[HP BOARD]**

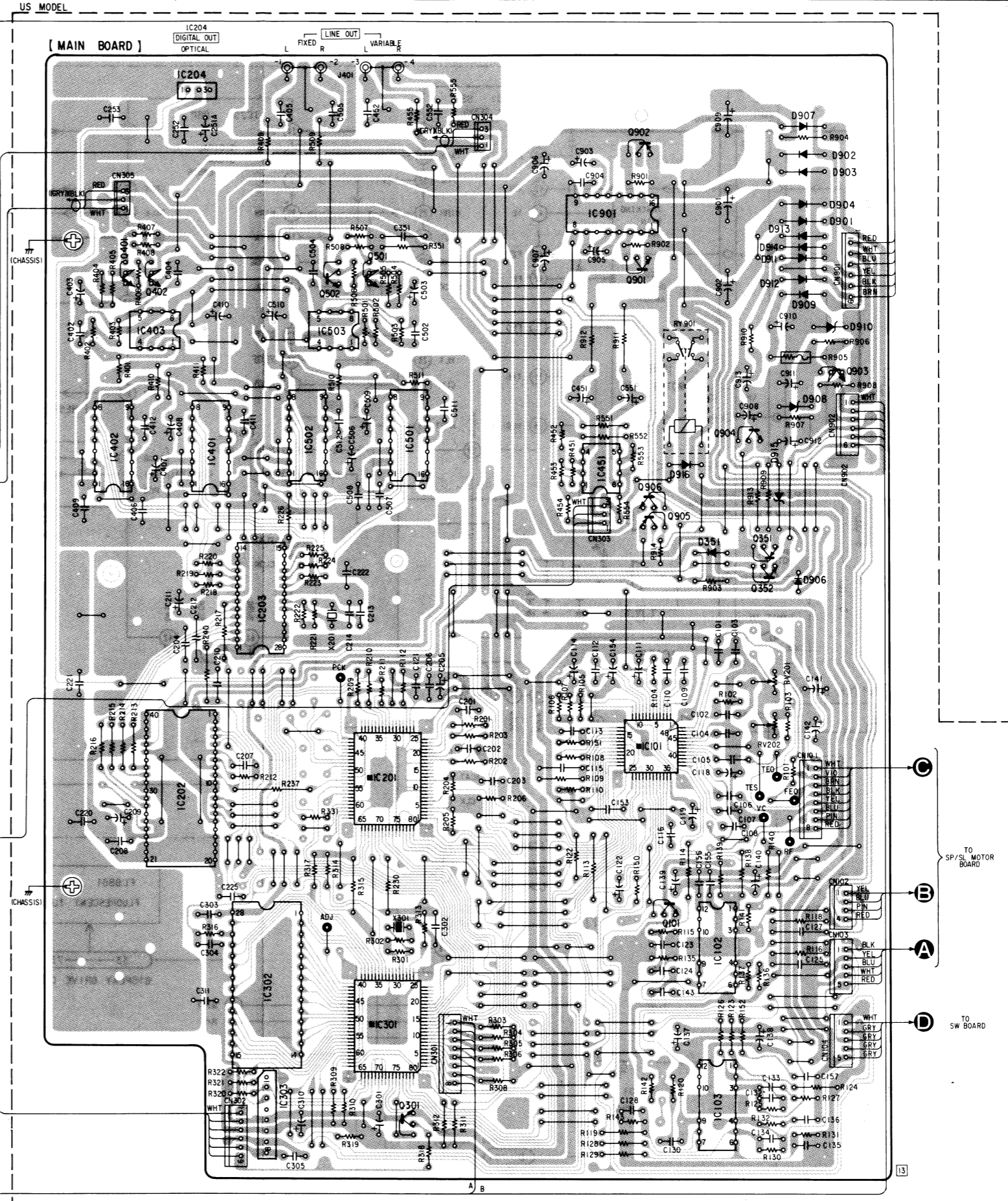
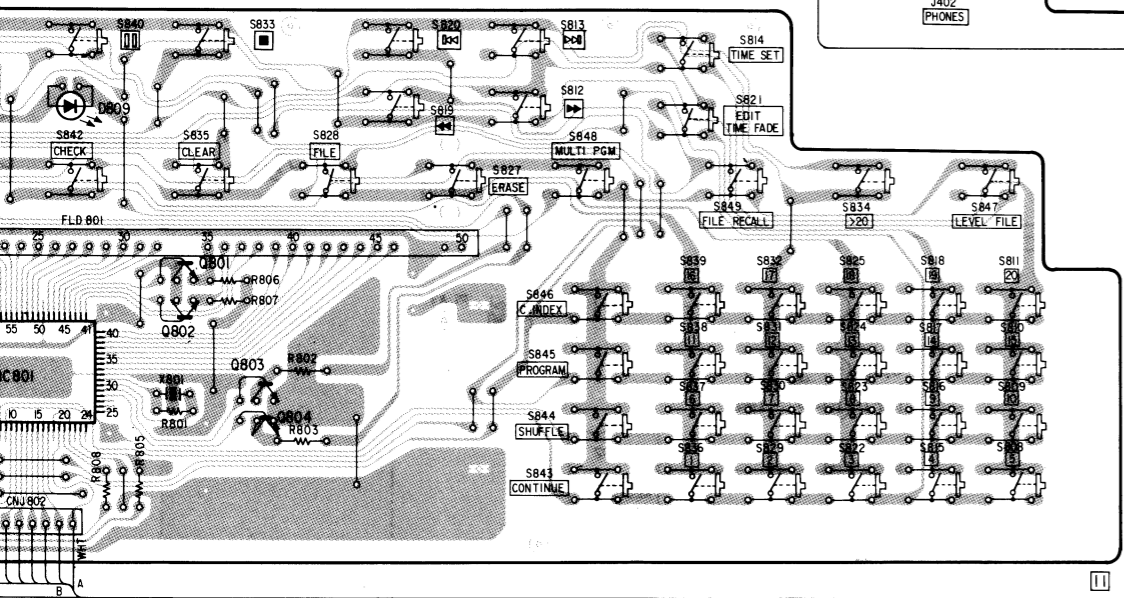
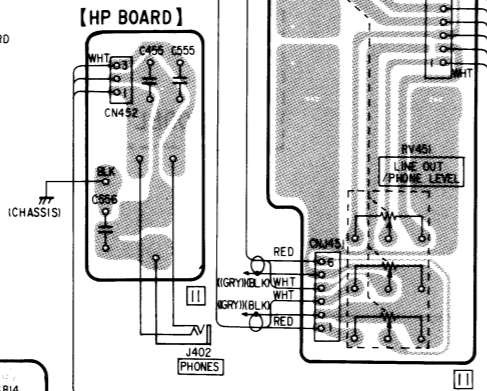



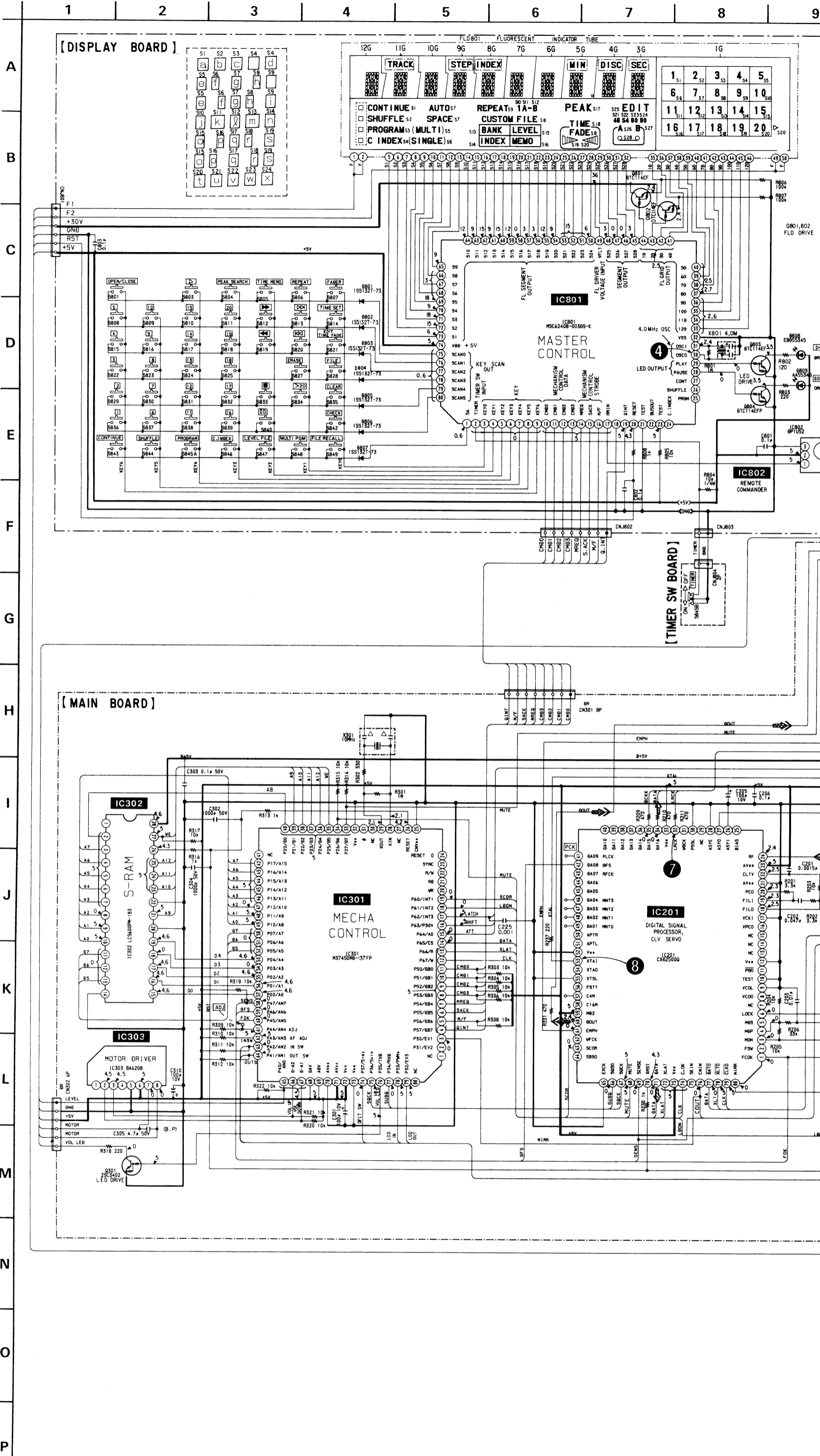

• WAVEFORM

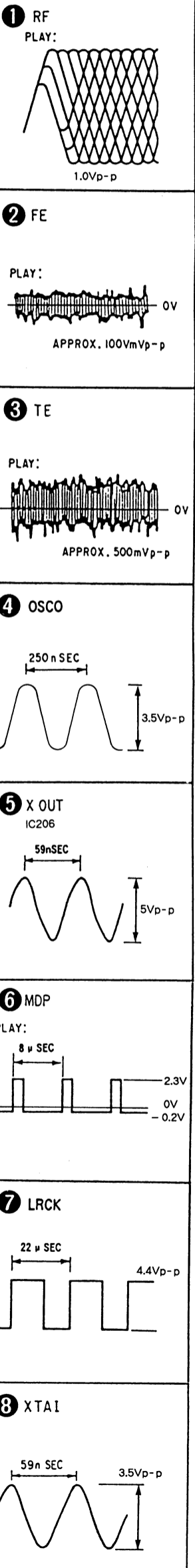

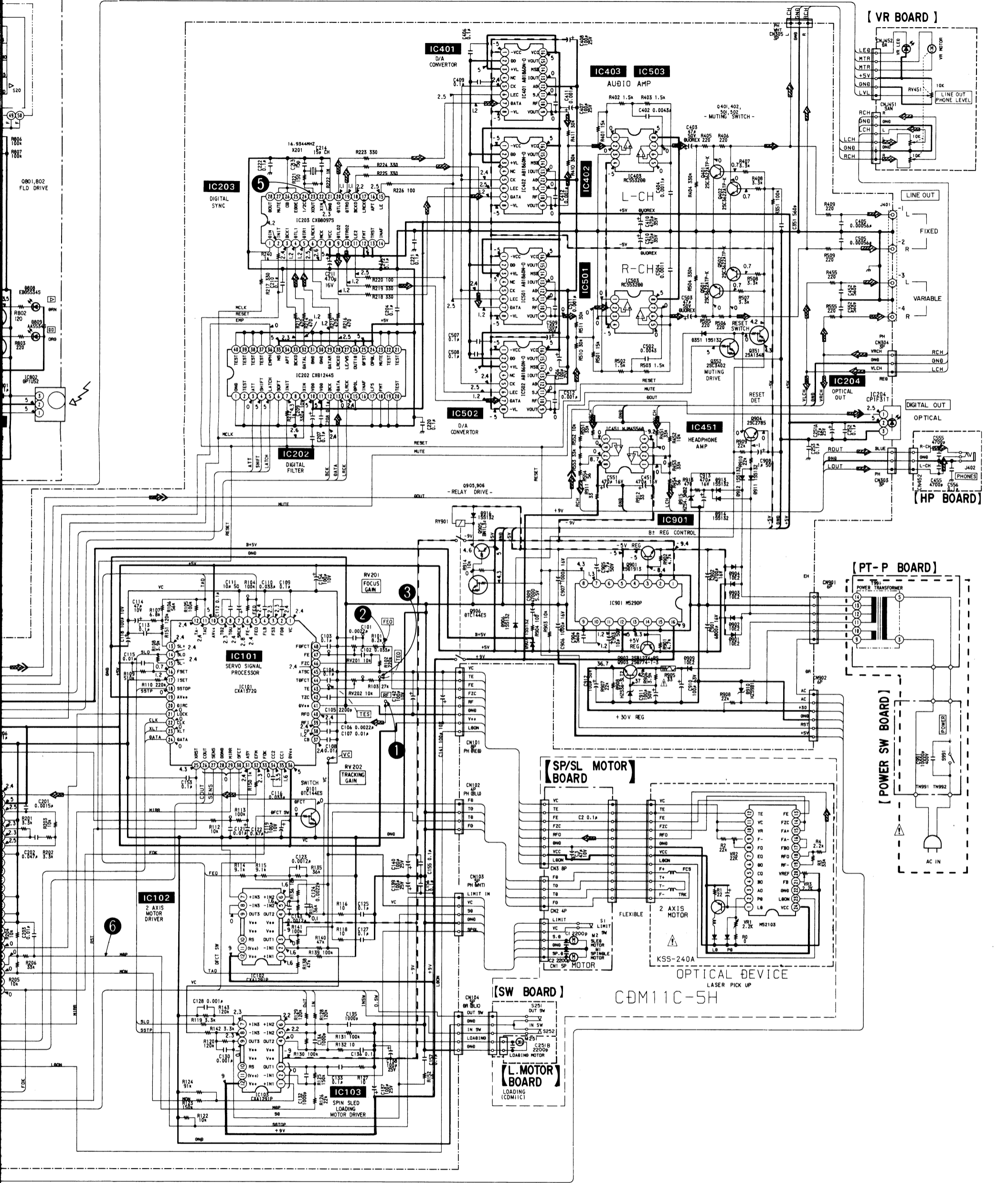

1 2 3 4 5 6 7 8 9 10 11

A  
B  
C  
D  
E  
F  
G  
H  
I  
J  
K  
L  
M  
N  
O  
P

[DISPLAY BOARD]

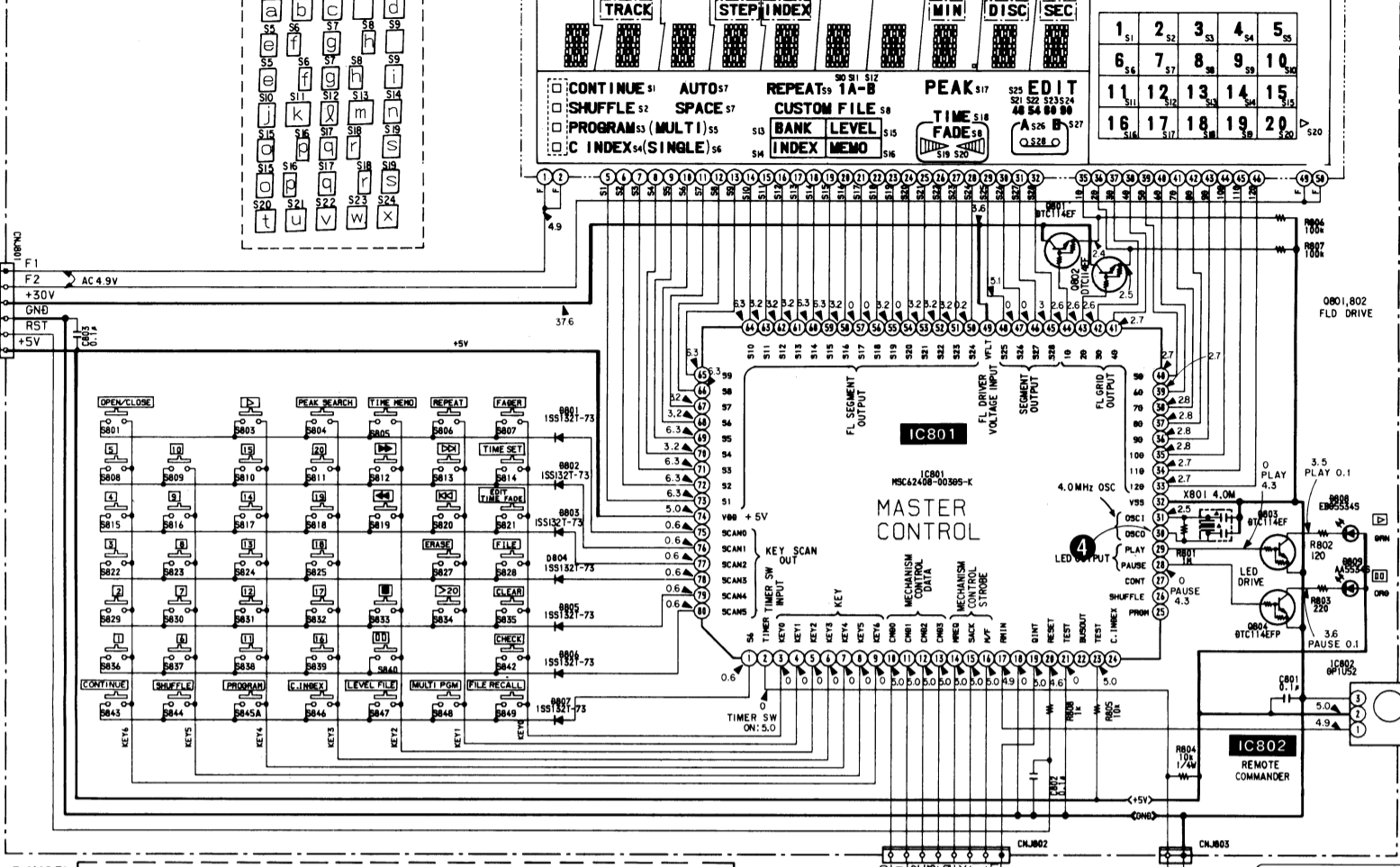

E MODEL

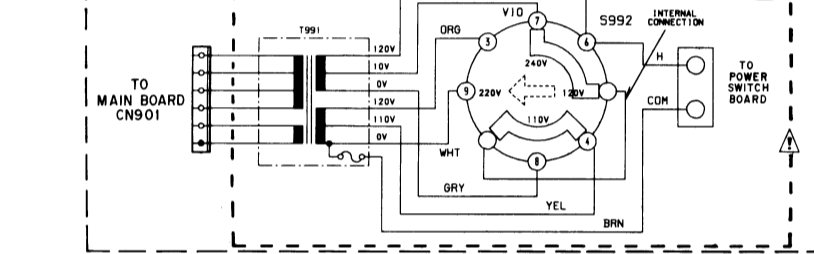

[MAIN BOARD]

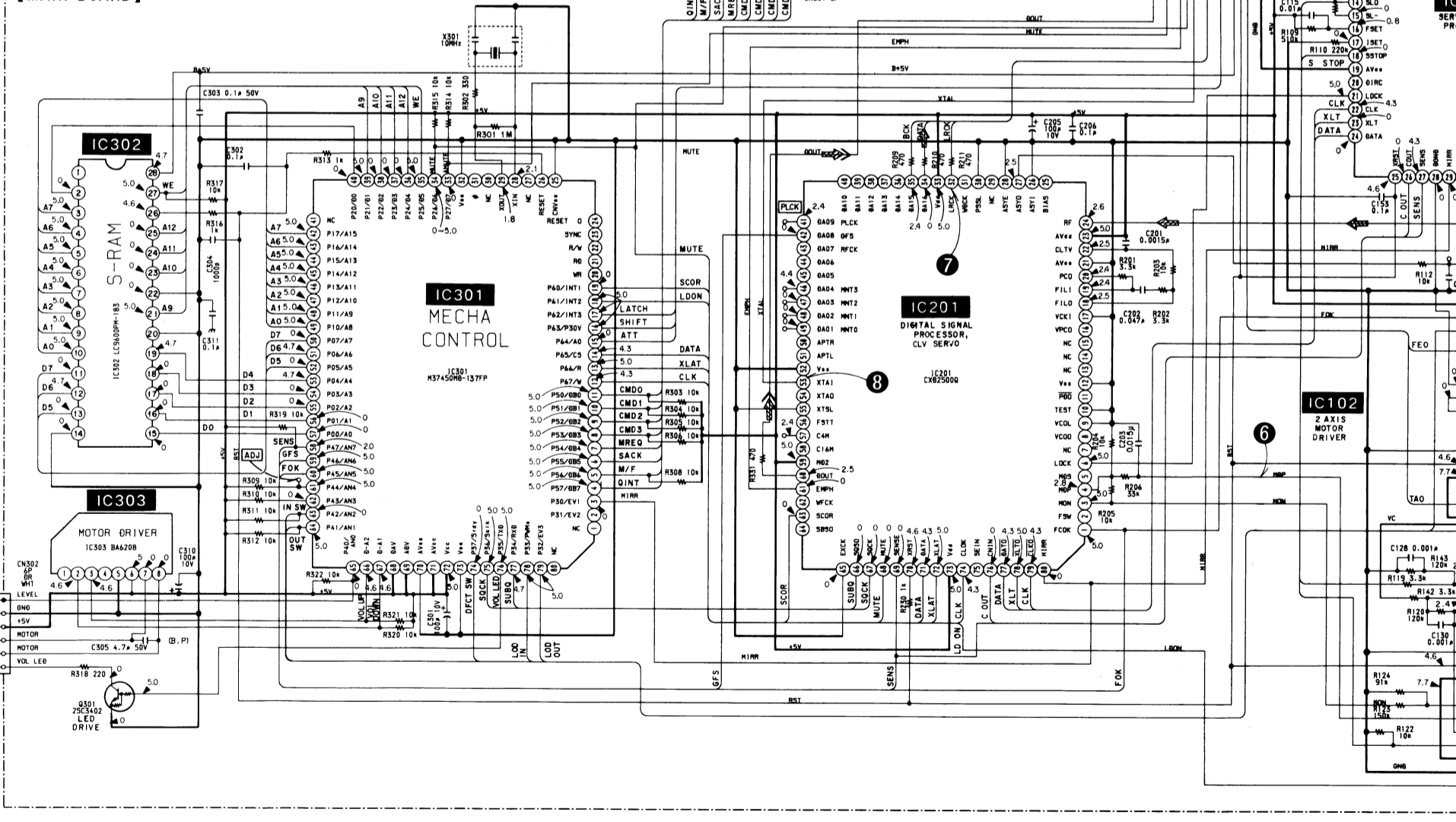

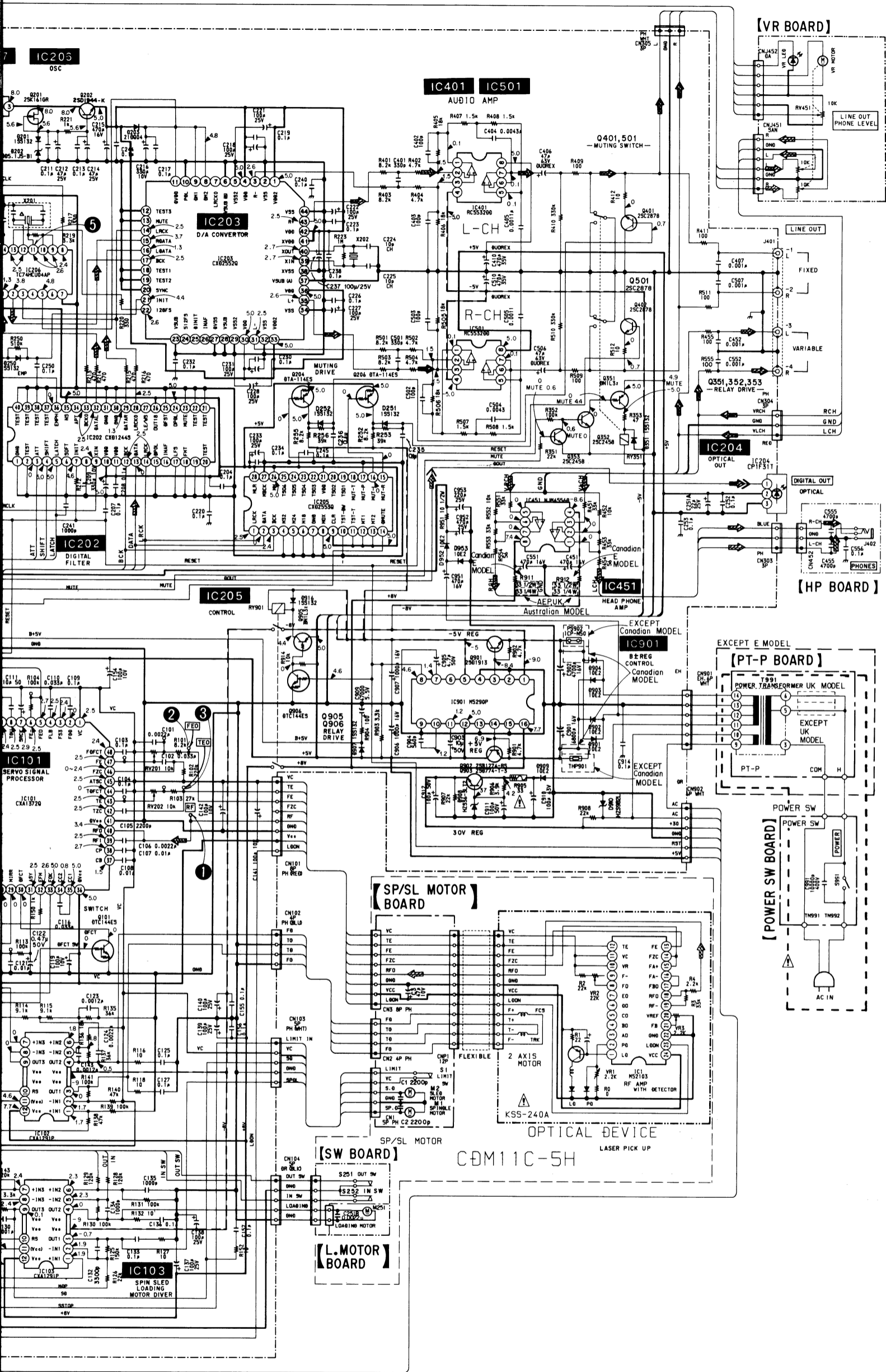

**Note on Schematic Diagram:**

- All capacitors are in  $\mu\text{F}$  unless otherwise noted.  $\text{pF}$ :  $\mu\text{F}$  50WV or less are not indicated except for electrolytics and tantalums.
- All resistors are in  $\Omega$  and  $1/4\text{W}$  or less unless otherwise specified.
- $\triangle$ : internal component.
- $\square$ : nonflammable resistor.
- $\text{---}/\text{---}$ : fusible resistor.

<p><b>Note:</b> The components identified by mark <math>\triangle</math> or dotted line with mark <math>\triangle</math> are critical for safety. Replace only with part number specified.</p>	<p><b>Note:</b> Les composants identifiés par une marque <math>\triangle</math> sont critiques pour la sécurité. Ne les remplacer que par une pièce portant le numéro spécifié.</p>
--	---

- $\text{---}$ : B+ Line
- $\text{---}$ : B- Line
- $\text{---}$ : adjustment for repair.
- Voltage and waveforms are dc with respect to ground under no-signal (detuned) conditions.  
no mark: PLAY
- Voltages are taken with a VOM (Input impedance 10M  $\Omega$ )  
Voltage variations may be noted due to normal production tolerances.
- Waveforms are taken with an oscilloscope.  
Voltage variations may be noted due to normal production tolerances.
- Circled numbers refer to waveforms.
- Signal path.  
 $\text{---}$ : CD  
 $\text{---}$ : digital out

4-10. PRINTED WIRING BOARDS (MAIN BOARD suffixed 11 )

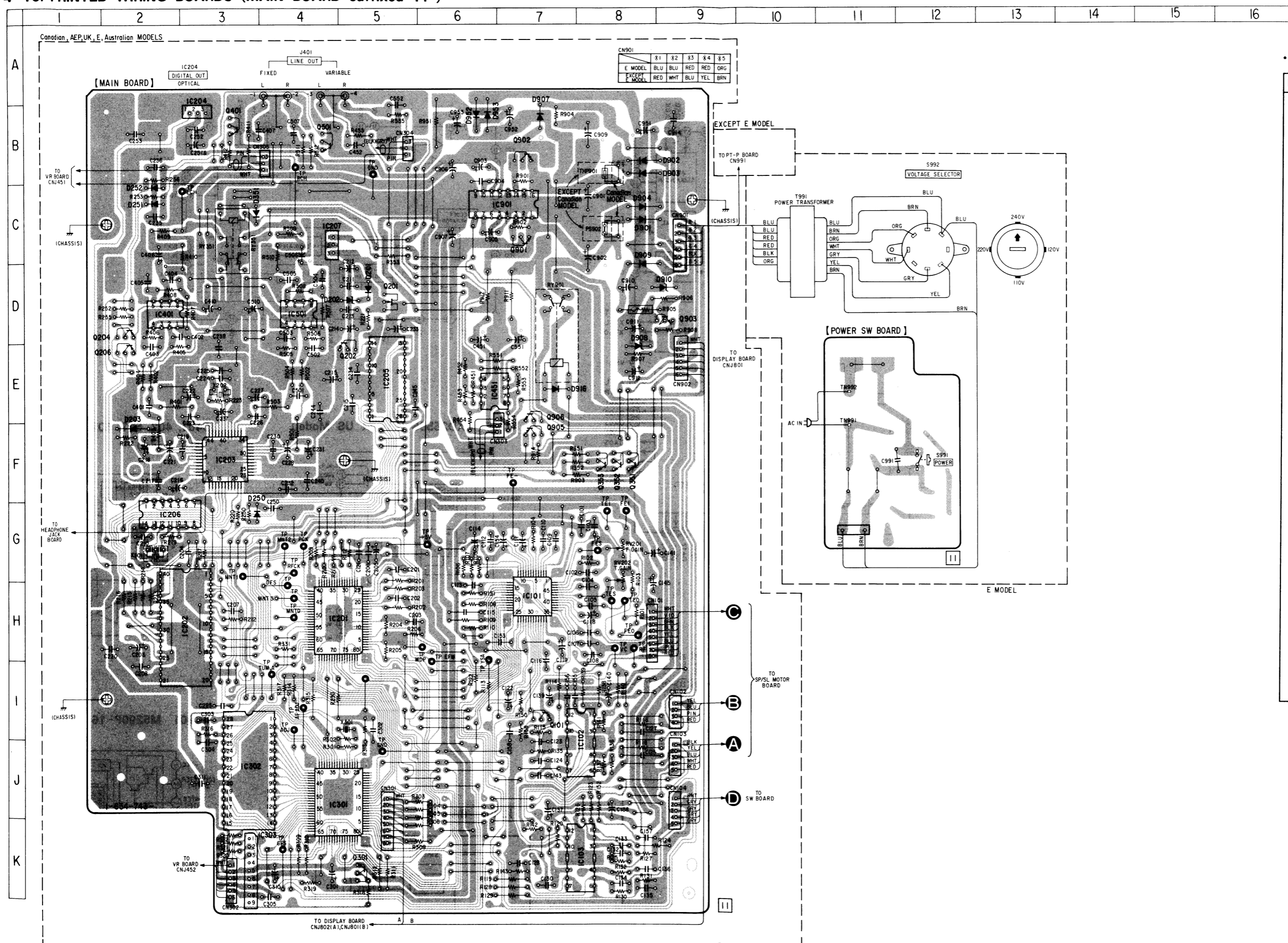

	X1	X2	X3	X4	X5
E MODEL	BLU	BLU	RED	RED	ORG
EXCEPT E MODEL	RED	WHT	BLU	YEL	BRN

• Semiconductor Location

Ref. No.	Location
D201	D-5
D202	D-4
D203	E-2
D250	F-3
D251	C-2
D252	B-2
D351	C-3
D901	C-8
D902	B-9
D903	B-9
D904	C-8
D907	A-7
D908	D-8
D909	C-8
D910	D-9
D916	E-8
D952	B-6
D953	B-6
IC101	H-7
IC102	I-8
IC103	K-8
IC201	H-4
IC202	H-3
IC203	F-3
IC204	A-3
IC205	E-5
IC206	G-2
IC207	C-4
IC301	J-4
IC302	J-3
IC303	K-4
IC401	D-2
IC451	E-6
IC501	D-4
IC901	C-7
Q101	I-7
Q201	D-5
Q202	F-5
Q204	D-2
Q206	F-2
Q301	K-5
Q351	F-8
Q352	F-8
Q353	F-8
Q401	B-3
Q501	B-4
Q901	C-7
Q902	B-7
Q903	D-9
Q905	F-7
Q906	E-7

• IC BLOCK DIAGRAM

IC101 CXA1372Q

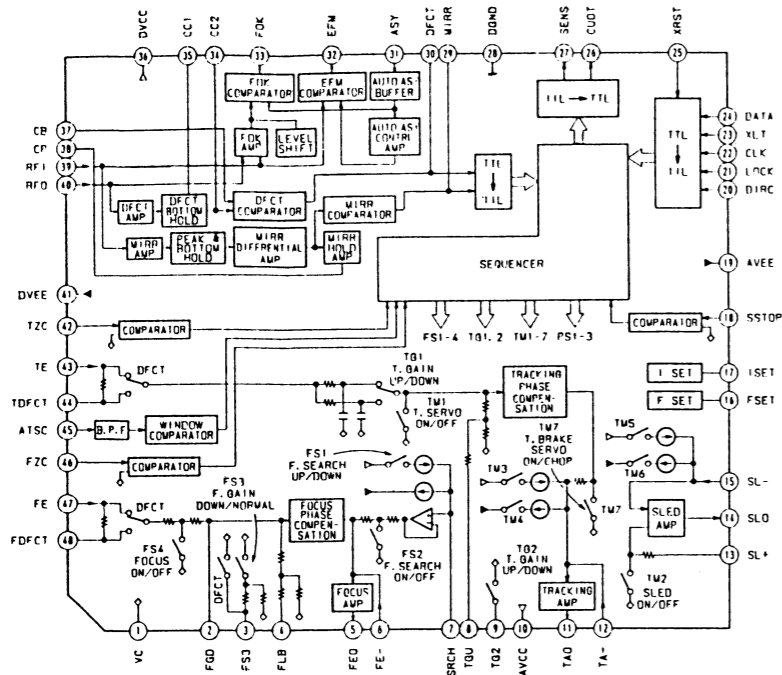

IC201 CXD2500Q

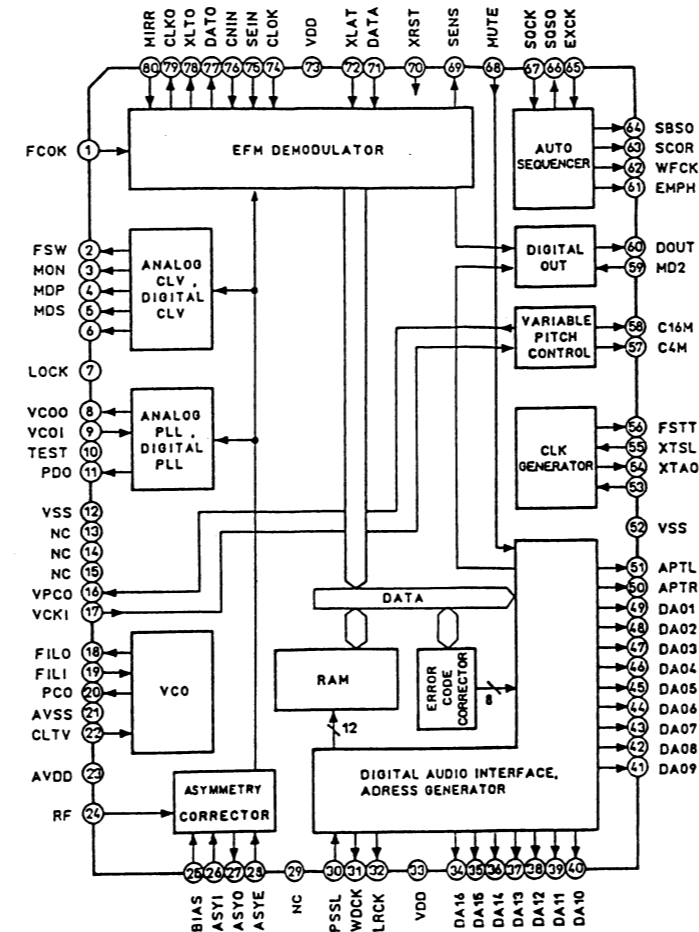

IC203 CXD2552Q (Except US Model)

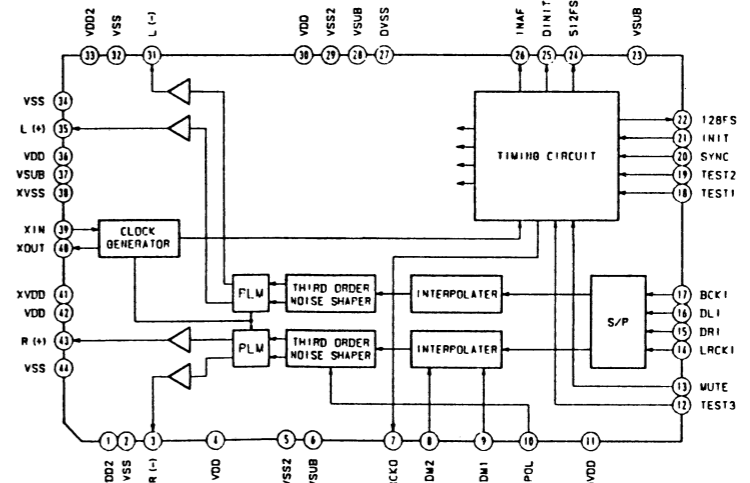

IC205 CXD2553S (Except US Model)

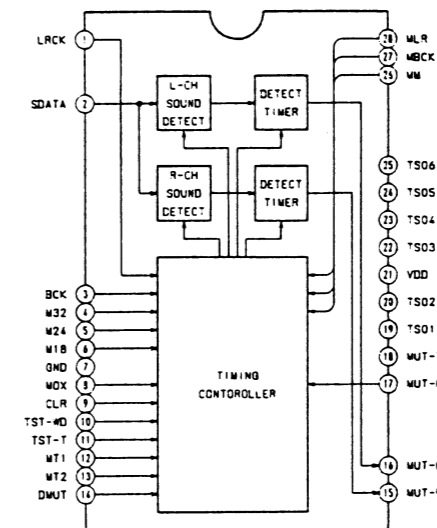

IC401, 402, 501, 502 AD1860N-K (US Model)

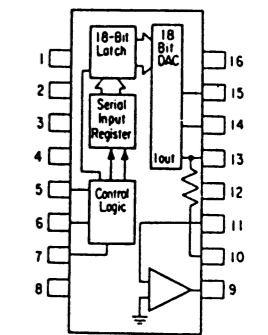

IC102, 103 CXA1291P

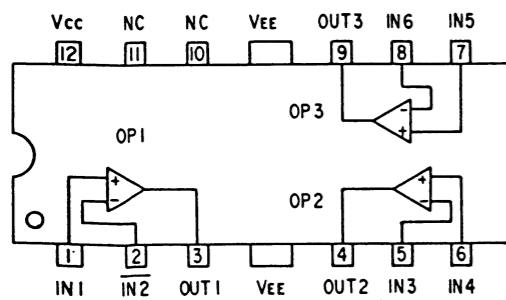

IC202 CXD1244S

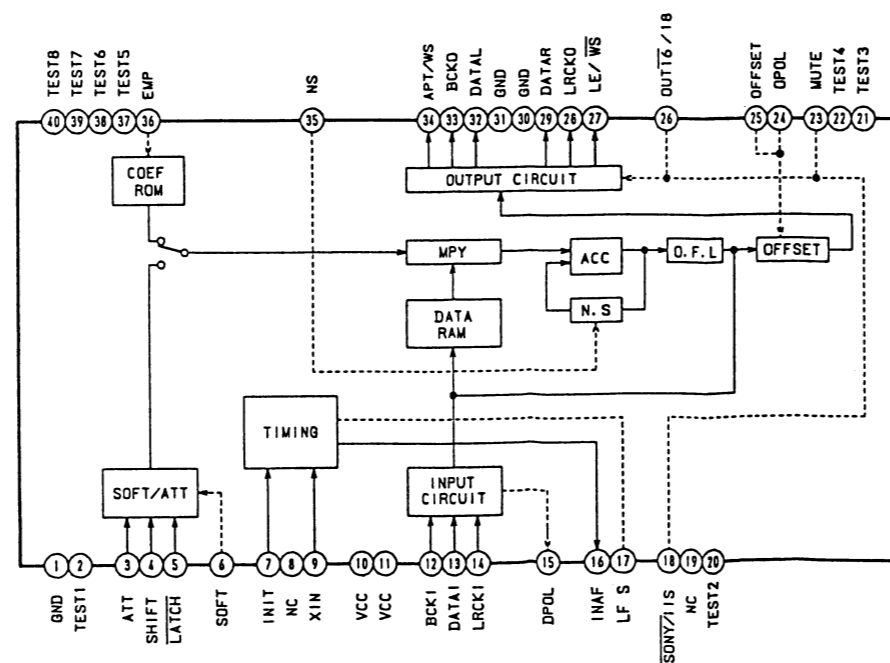

IC303 BA6208

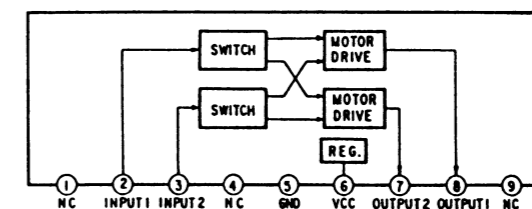

IC901 M5290P-16

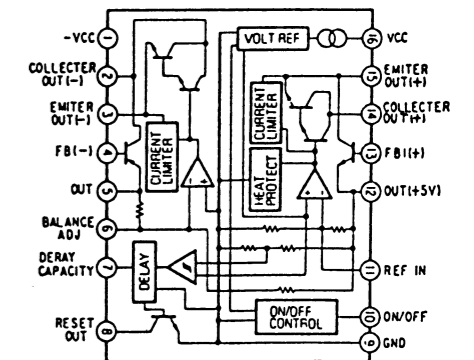

## SECTION 5 EXPLODED VIEWS

### NOTE:

- The mechanical parts with no reference number in the exploded views are not supplied.
- The construction parts of an assembled part are indicated with a collation number in the remark column.
- Items marked "\*" are not stocked since they are seldom required for routine service. Some delay should be anticipated when ordering these items.

- Due to standardization, parts with part number suffix -XX and -X may be different from the parts specified in the components used on the set.
- Color Indication of Appearance Parts Example:  
(RED) ... KNOB, BALANCE (WHITE)

↑ Cabinet's Color      ↑ Parts' Color

The components identified by mark or dotted line with mark are critical for safety. Replace only with part number specified.

Les composants identifiés par une marque sont critiques pour la sécurité. Ne les remplacer que par une pièce portant le numéro spécifié.

### 5-1. OVERALL SECTION

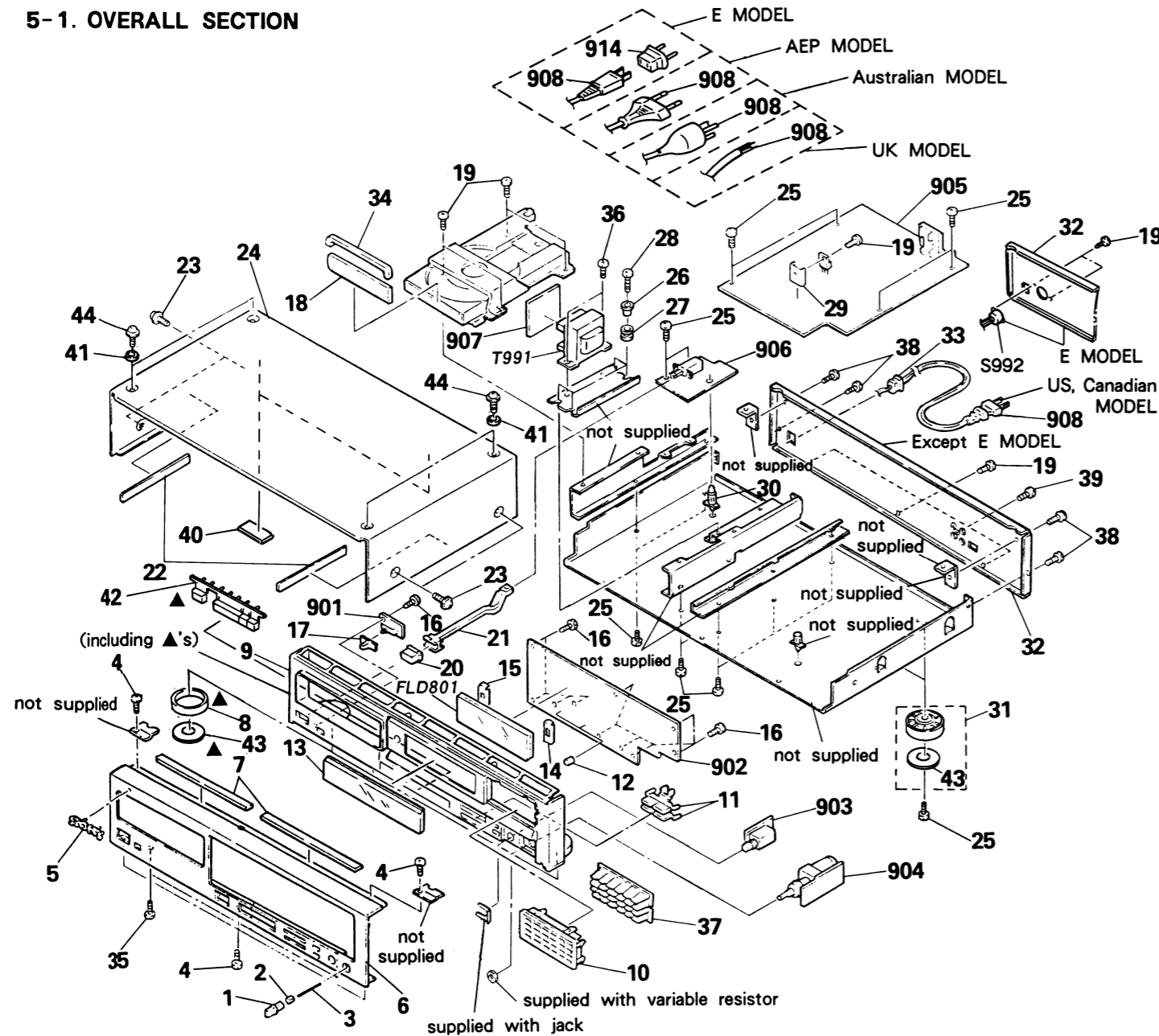

No.	Part No.	Description	Remarks	No.	Part No.	Description	Remarks
1	4-922-977-01	KNOB (HP)		33	*3-703-244-00 3-703-571-11	(EXCEPT E)...BUSHING (2104), CORD (E)...BUSHING (S)(4516), CORD PA	
2	4-922-978-01	HOLDER (FIBER)		34	*4-929-016-01	STOPPER, DISC TABLE	
3	4-922-979-11	INDICATOR		35	3-703-685-21	SCREW (+BV 3X8)	
4	7-685-534-19	SCREW +BTP 2.6X8 TYPE2 N-S		36	4-886-821-11	SCREW, S TIGHT, +PTTWH 3X6	
5	4-908-848-01	EMBLEM, SONY		37	4-929-527-01	BUTTON (M/C)	
6	4-934-010-01	(UK,Australian)...PANEL (FRONT)		38	7-682-548-09	SCREW +BVTT 3X8 (S)	
	4-934-010-11	(AEP,E).....PANEL (FRONT)		39	7-685-646-79	SCREW +BVTP 3X8 TYPE2 N-S	
	4-934-010-22	(US,Canadian).....PANEL (FRONT)		40	*4-922-943-01	DUMPER	
7	*4-929-557-01	CUSHION (PANEL)		41	4-928-025-11	ESCUTCHEON (TOP PLATE)	
8	4-934-091-01	(AEP,UK,E,Australian)...RING (DIA.58A), ORNAMENTAL		42	X-4934-002-1	BUTTON (A) ASSY	
9	X-4934-001-1	(AEP,UK,Australian)...PANEL ASSY, SUB		43	4-923-836-11	CUSHION	
	X-4934-017-1	(US,Canadian).....PANEL ASSY, SUB		44	3-721-187-01	SCREW (3X8)	
10	4-934-006-01	ESCUTCHEON (24)		901	*1-632-652-11	PC BOARD, TIMER SWITCH	
11	4-934-019-01	BUTTON (AMS)		902	*A-4617-206-A	MOUNTED PCB, DISPLAY	
12	*4-923-532-01	SPACER, LED		903	*1-632-653-11	PC BOARD, HP	
13	4-934-016-01	PLATE, INDICATION		904	*1-632-654-11	PC BOARD, VR	
14	*4-922-523-01	HOLDER (RIGHT)		905	*A-4617-304-A	(US).....MOUNTED PCB, MAIN	
15	*4-922-524-01	HOLDER (LEFT)			*A-4617-307-A	(AEP,UK,Australian)...MOUNTED PCB, MAIN	
16	7-685-134-19	SCREW +BTP 2.6X8 TYPE2 N-S			*A-4617-310-A	(E).....MOUNTED PCB, MAIN	
17	4-922-518-11	KNOB (TIMER)			*A-4617-500-A	(Canadian).....MOUNTED PCB, MAIN	
18	4-934-021-01	(AEP,UK,E,Australian)...PANEL, LOADING		906	*1-632-649-11	(US).....PC BOARD, POWER SWITCH	
	4-934-021-11	(US).....PANEL, LOADING			*1-634-744-11	(EXCEPT US)...PC BOARD, POWER SWITCH	
	4-934-021-21	(Canadian).....PANEL, LOADING		907	*1-632-650-11	(US).....PCB, PT-P	
19	7-682-547-04	SCREW +BVTT 3X6 (S)			*1-634-745-11	(Canadian,AEP,UK,Australian) ...PC BOARD, PT-T	
20	4-923-520-01	KNOB, POWER		908	.1-555-795-00	(AEP)....CORD, POWER, EULO PLUG	
21	4-934-015-01	LEVER (POWER)			.1-556-035-00	(UK).....CORD, POWER	
22	*4-929-561-01	CUSHION (CASE)			.1-556-091-00	(E).....CORD, POWER	
23	3-704-366-31	SCREW (CASE) (M3X6)			.1-557-577-11	(US,Canadian)...CORD, POWER	
24	4-934-008-01	CASE			.1-574-904-11	(Australian)....CORD, POWER	
25	7-682-548-04	SCREW +BVTT 3X8 (S)		914	.1-526-565-00	AC PLUG ADAPTOR	
26	4-928-032-01	COLLAR (A)		S992	.1-526-576-51	(E)...SELECTOR, POWER VOLTAGE (VOLTAGE SELECTOR)	
27	*4-888-798-00	BUSHING, RUBBER		T991	.1-449-578-11	(US,Canadian).....TRANSFORMER, POWER	
28	7-682-549-04	SCREW +BVTT 3X10 (S)		T991	.1-449-579-11	(AEP,UK,Australian)...TRANSFORMER, POWER	
29	*4-886-555-00	HEAT SINK		T991	.1-449-580-11	(E).....TRANSFORMER, POWER	
30	*3-703-353-07	SUPPORT, PC BOARD					
31	X-4934-012-1	FOOT ASSY					
32	*4-934-001-21	(US).....PANEL, BACK					
	*4-934-001-41	(Canadian).....PANEL, BACK					
	*4-934-001-61	(AEP).....PANEL, BACK					
	*4-934-001-71	(UK,Australian)...PANEL, BACK					
	*4-934-001-81	(E).....PANEL, BACK					

**Note:**  
The components identified by mark or dotted line with mark are critical for safety. Replace only with part number specified.

**Note:**  
Les composants identifiés par une marque sont critiques pour la sécurité. Ne les remplacer que par une pièce portant le numéro spécifié.

5-2. MD SECTION (CDM11C-5H)

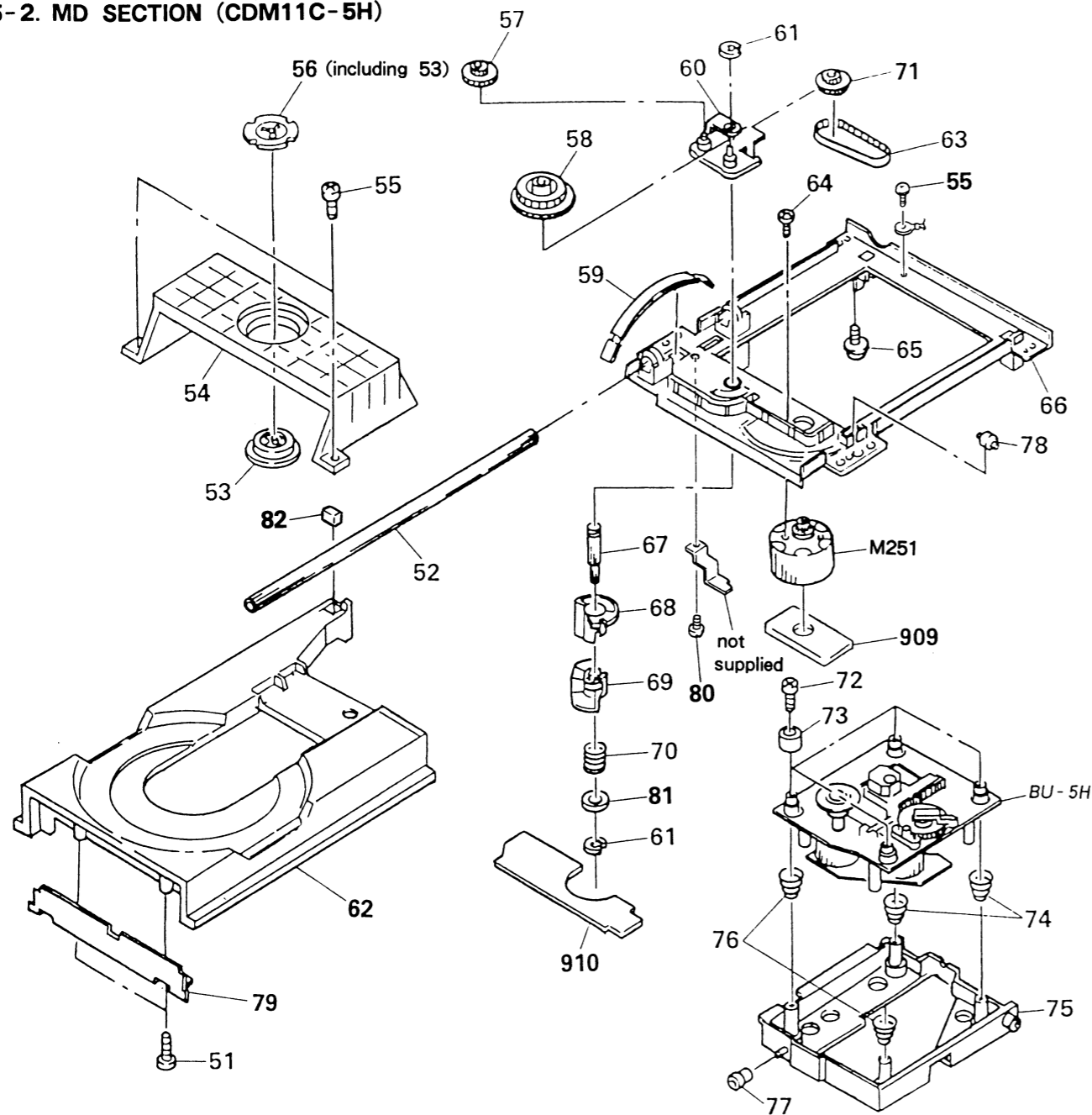

No.	Part No.	Description
51	7-685-647-79	SCREW +P 3X10 TYPE2 SLIT
52	4-927-617-01	BAR, GUIDE
53	*4-918-679-04	PULLEY, PRESS
54	*4-927-638-03	HOLDER (A,P)
55	7-621-770-67	SCREW +BVT 2.6X6 (S)
56	A-4665-024-A	MAGNET ASSY
57	4-927-628-01	GEAR (C)
58	4-927-620-01	GEAR (P)
59	*4-927-648-01	SLIDER (GROUND)
60	X-4927-608-1	ARM ASSY, SWING
61	7-624-105-04	STOP RING 2.3, TYPE -E
62	*4-927-642-01	TABLE (EXL), DISC
63	4-927-649-01	BELT
64	7-621-775-08	SCREW +P 2.6X3
65	*4-917-583-21	BRACKET, YOKE
66	*4-927-641-04	CHASSIS (OUTSERT), MECAHNICAL
67	4-927-665-01	SHAFT (S)
68	4-927-624-01	CAM (L,A)

No.	Part No.	Description
69	4-927-635-01	CAM (L,B)
70	3-659-338-00	SPRING, COMPRESSION
71	4-929-724-01	PULLEY (B)
72	7-685-134-19	SCREW +BTP 2.6X8 TYPE2 N-S
73	4-927-634-01	HOLDER (SP)
74	4-917-541-01	SPRING (B)
75	*4-927-640-03	HOLDER (BU-5)
76	4-917-572-01	SPRING (B)
77	4-927-631-01	ROLLER (L)
78	4-927-627-01	ROLLER (S,G)
79	*4-927-652-01	REINFORCEMENT
80	7-621-773-86	SCREW +BVT 2.6X4 (S)
81	4-927-654-01	WASHER (LIMITER)
82	*4-927-670-01	CUSHION (MD)
909	*1-629-359-11	PC BOARD, L.MOTOR
910	*1-629-360-11	PC BOARD, SWITCH
M251	A-4608-362-A	MOTOR (L) ASSY (LOADING)

5-3. OPTICAL PICK-UP BLOCK (BU-5H)

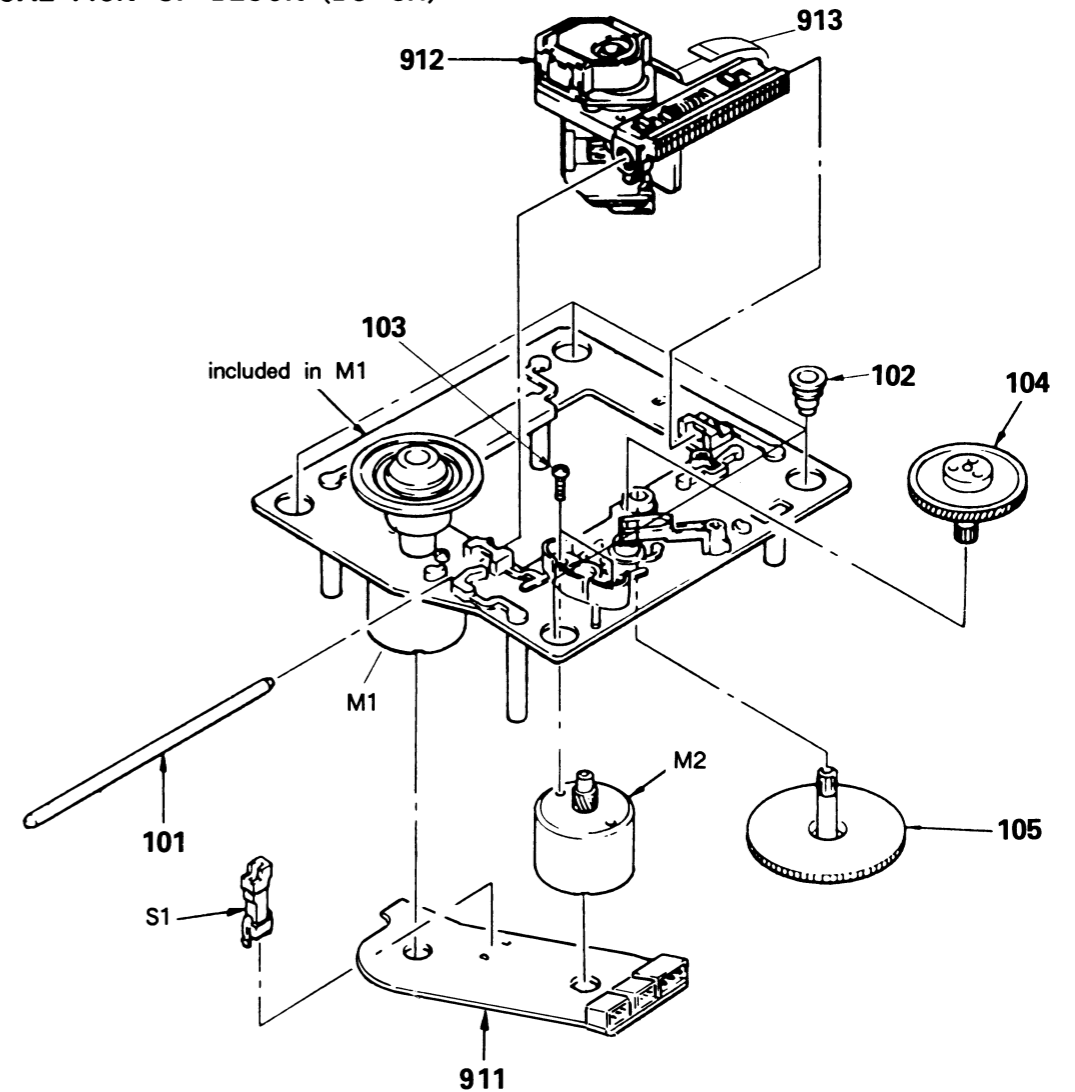

**Note:**  
The components identified by mark  $\Delta$  or dotted line with mark  $\Delta$  are critical for safety. Replace only with part number specified.

**Note:**  
Les composants identifiés par une marque  $\Delta$  sont critiques pour la sécurité. Ne les remplacer que par une pièce portant le numéro spécifié.

No.	Part No.	Description
101	4-917-565-01	SHAFT, SLED
102	4-917-584-01	INSULATOR
103	7-621-255-15	SCREW +P 2X3
104	4-917-567-01	GEAR (M)
105	4-917-564-01	GEAR (P), FLATNESS

No.	Part No.	Description
911	*1-632-711-11	PC BOARD, SP/SL MOTOR
912	$\Delta$ 8-848-144-11	DEVICE, OPTICAL KSS-240A
913	1-575-003-11	WIRE, FLAT TYPE (12 CORE)
M1	X-4917-523-1	MOTOR ASSY, SPINDLE
M2	X-4917-504-1	MOTOR ASSY, SLED
S1	1-572-085-11	SWITCH, LEAF



## SECTION 6 ELECTRICAL PARTS LIST

**NOTE:**

- Due to standardization, replacements in the parts list may be different from the parts specified in the diagrams or the components used on the set.
- Items marked "★" are not stocked since they are seldom required for routine service. Some delay should be anticipated when ordering these items.
- If there are two or more same circuits in a set such as a stereophonic machine, only typical circuit parts may be indicated and capacitors and resistors in other same circuits may be omitted.

**CAPACITORS:**  
MF:  $\mu$ F, PF:  $\mu$  $\mu$ F.

**RESISTORS**  
• All resistors are in ohms.  
• F: nonflammable

**COILS**  
• MMH: mH, UH:  $\mu$ H

**SEMICONDUCTORS**  
In each case, U:  $\mu$ , for example:  
UA....:  $\mu$ A...., UPA....:  $\mu$ PA....,  
UPC....:  $\mu$ PC, UPD....:  $\mu$ PD....

The components identified by mark  $\Delta$  or dotted line with mark  $\Delta$  are critical for safety. Replace only with part number specified.

Les composants identifiés par une marque  $\Delta$  sont critiques pour la sécurité. Ne les remplacer que par une pièce portant le numéro spécifié.

Ref.No.	Part No.	Description	Ref.No.	Part No.	Description
901	*1-632-652-11	PC BOARD, TIMER SWITCH	C121	1-136-153-00	FILM 0.01MF 5% 50V
902	*A-4617-206-A	MOUNTED PCB, DISPLAY	C122	1-126-300-11	ELECT 0.47MF 20% 50V
903	*1-632-653-11	PC BOARD, HP	C123	1-130-472-00	MYLAR 0.0012MF 5% 50V
904	*1-632-654-11	PC BOARD, VR	C124	1-130-475-00	MYLAR 0.0022MF 5% 50V
905	*A-4617-304-A	(US).....MOUNTED PCB, MAIN	C125	1-164-159-11	CERAMIC 0.1MF 50V
	*A-4617-307-A	(AEP,UK,Australian)..MOUNTED PCB, MAIN	C127	1-164-159-11	CERAMIC 0.1MF 50V
	*A-4617-310-A	(E).....MOUNTED PCB, MAIN	C128	1-130-471-00	MYLAR 0.001MF 5% 50V
	*A-4617-500-A	(Canadian).....MOUNTED PCB, MAIN	C130	1-130-471-00	MYLAR 0.001MF 5% 50V
906	*1-632-649-11	(US).....PC BOARD, POWER SWITCH	C132	1-161-327-00	CERAMIC 0.0033MF 30% 16V
	*1-634-744-11	(EXCEPT US)....PC BOARD, POWER SWITCH	C133	1-164-159-11	CERAMIC 0.1MF 50V
907	*1-632-650-11	(US).....PCB, PT-P	C134	1-162-294-31	CERAMIC 0.001MF 10% 50V
	*1-634-745-11	(Canadian,AEP,UK,Australian) ...PC BOARD, PT-T	C135	1-162-294-31	CERAMIC 0.001MF 10% 50V
908	$\Delta$ 1-555-795-00	(AEP)....CORD, POWER, EULO PLUG	C136	1-164-159-11	CERAMIC 0.1MF 50V
	$\Delta$ 1-556-035-00	(UK).....CORD, POWER	C137	1-124-478-11	ELECT 100MF 20% 25V
	$\Delta$ 1-556-091-00	(E).....CORD, POWER	C138	1-124-478-11	ELECT 100MF 20% 25V
	$\Delta$ 1-557-577-11	(US,Canadian)....CORD, POWER	C139	1-124-478-11	ELECT 100MF 20% 25V
	$\Delta$ 1-574-904-11	(Australian)....CORD, POWER	C140	1-124-478-11	ELECT 100MF 20% 25V
909	*1-629-359-11	PC BOARD, L.MOTOR	C141	1-124-994-11	ELECT 100MF 20% 10V
910	*1-629-360-11	PC BOARD, SWITCH	C142	1-124-994-11	ELECT 100MF 20% 10V
911	*1-632-711-11	PC BOARD, SP/SL MOTOR	C143	1-130-472-00	MYLAR 0.0012MF 5% 50V
912	$\Delta$ 8-848-144-11	DEVICE, OPTICAL KSS-240A	C153	1-164-159-11	CERAMIC 0.1MF 50V
913	1-575-003-11	WIRE, FLAT TYPE (12 CORE)	C154	1-124-994-11	ELECT 100MF 20% 10V
914	$\Delta$ 1-526-565-00	AC PLUG ADAPTOR	C155	1-164-159-11	CERAMIC 0.1MF 50V
BP901	*1-535-139-00	(E)...BASE POST 19MM 2P	C156	1-164-159-11	CERAMIC 0.1MF 50V
C1	1-130-475-00	MYLAR 0.0022MF 5% 50V	C157	1-164-159-11	CERAMIC 0.1MF 50V
C2	1-130-475-00	MYLAR 0.0022MF 5% 50V	C201	1-130-473-00	MYLAR 0.0015MF 5% 50V
C3	1-124-589-11	ELECT 47MF 20% 16V	C202	1-136-161-00	FILM 0.047MF 5% 50V
C101	1-130-475-00	MYLAR 0.0022MF 5% 50V	C203	1-136-155-00	FILM 0.015MF 5% 50V
C102	1-136-159-00	FILM 0.033MF 5% 50V	C204	1-164-159-11	CERAMIC 0.1MF 50V
C103	1-136-165-00	FILM 0.1MF 5% 50V	C205	1-124-994-11	ELECT 100MF 20% 10V
C104	1-136-165-00	FILM 0.1MF 5% 50V	C206	1-164-159-11	CERAMIC 0.1MF 50V
C105	1-161-375-00	CERAMIC 0.0022MF 20% 16V	C207	1-164-159-11	CERAMIC 0.1MF 50V
C106	1-130-475-00	MYLAR 0.0022MF 5% 50V	C208	1-164-159-11	(US).....CERAMIC 0.1MF 50V
C107	1-136-153-00	FILM 0.01MF 5% 50V	C208	1-162-179-11	(EXCEPT US)...CERAMIC 0.1MF 50V
C108	1-136-153-00	FILM 0.01MF 5% 50V	C209	1-124-604-00	ELECT 330MF 20% 10V
C109	1-136-165-00	FILM 0.1MF 5% 50V	C210	1-136-165-00	(EXCEPT US)...FILM 0.1MF 5% 50V
C110	1-136-159-00	FILM 0.033MF 5% 50V	C210	1-164-159-11	(US).....CERAMIC 0.1MF 50V
C111	1-126-059-11	ELECT 10MF 20% 50V	C211	1-126-012-11	(US).....ELECT 470MF 20% 16V
C112	1-136-165-00	FILM 0.1MF 5% 50V	C211	1-136-165-00	(EXCEPT US)...FILM 0.1MF 5% 50V
C113	1-136-165-00	FILM 0.1MF 5% 50V	C212	1-124-910-11	(EXCEPT US)...ELECT 47MF 20% 25V
C114	1-126-022-11	ELECT 47MF 20% 10V	C212	1-164-159-11	(US).....CERAMIC 0.1MF 50V
C115	1-162-306-11	CERAMIC 0.01MF 20% 16V	C213	1-136-165-00	(EXCEPT US)...FILM 0.1MF 5% 50V
C116	1-136-159-00	FILM 0.033MF 5% 50V	C213	1-162-203-31	(US).....CERAMIC 15PF 5% 50V
C118	1-124-994-11	ELECT 100MF 20% 10V			
C119	1-124-994-11	ELECT 100MF 20% 10V			

Ref.No.	Part No.	Description			
C214	1-124-910-11	(EXCEPT US)...ELECT	47MF	20%	25V
C214	1-162-203-31	(US).....CERAMIC	15PF	5%	50V
C215	1-126-103-11	(EXCEPT US)...ELECT	470MF	20%	16V
C216	1-124-604-00	(EXCEPT US)...ELECT	330MF	20%	10V
C217	1-136-165-00	(EXCEPT US)...FILM	0.1MF	5%	50V
C218	1-124-478-11	(EXCEPT US)...ELECT	100MF	20%	25V
C219	1-136-165-00	(EXCEPT US)...FILM	0.1MF	5%	50V
C220	1-162-179-11	(EXCEPT US)...CERAMIC	0.1MF		50V
C220	1-164-159-11	(US).....CERAMIC	0.1MF		50V
C221	1-124-478-11	(EXCEPT US)...ELECT	100MF	20%	25V
C221	1-164-159-11	(US).....CERAMIC	0.1MF		50V
C222	1-124-478-11	(EXCEPT US)...ELECT	100MF	20%	25V
C222	1-164-159-11	(US).....CERAMIC	0.1MF		50V
C223	1-136-165-00	(EXCEPT US)...FILM	0.1MF	5%	50V
C224	1-162-199-31	(EXCEPT US)...CERAMIC	10PF	5%	50V
C225	1-162-199-31	(EXCEPT US)...CERAMIC	10PF	5%	50V
C225	1-162-294-31	(US).....CERAMIC	0.001MF	10%	50V
C226	1-136-165-00	(EXCEPT US)...FILM	0.1MF	5%	50V
C227	1-124-478-11	(EXCEPT US)...ELECT	100MF	20%	25V
C228	1-124-478-11	(EXCEPT US)...ELECT	100MF	20%	25V
C230	1-136-165-00	(EXCEPT US)...FILM	0.1MF	5%	50V
C231	1-124-478-11	(EXCEPT US)...ELECT	100MF	20%	25V
C232	1-162-179-11	(EXCEPT US)...CERAMIC	0.1MF		50V
C233	1-124-478-11	(EXCEPT US)...ELECT	100MF	20%	25V
C234	1-164-159-11	(EXCEPT US)...CERAMIC	0.1MF		50V
C235	1-136-165-00	(EXCEPT US)...FILM	0.1MF	5%	50V
C236	1-136-165-00	(EXCEPT US)...FILM	0.1MF	5%	50V
C237	1-124-478-11	(EXCEPT US)...ELECT	100MF	20%	25V
C238	1-136-165-00	(EXCEPT US)...FILM	0.1MF	5%	50V
C240	1-162-179-11	(EXCEPT US)...CERAMIC	0.1MF		50V
C241	1-162-294-31	(EXCEPT US)...CERAMIC	0.001MF	10%	50V
C244	1-136-165-00	(EXCEPT US)...FILM	0.1MF	5%	50V
C245	1-136-165-00	(EXCEPT US)...FILM	0.1MF	5%	50V
C250	1-136-165-00	(EXCEPT US)...FILM	0.1MF	5%	50V
C251A	1-126-049-11	ELECT	22MF	20%	25V
C251B	1-136-157-00	FILM	0.022MF	5%	50V
C252	1-162-179-11	(EXCEPT US)...CERAMIC	0.1MF		50V
C252	1-164-159-11	(US).....CERAMIC	0.1MF		50V
C253	1-162-179-11	(EXCEPT US)...CERAMIC	0.1MF		50V
C253	1-164-159-11	(US).....CERAMIC	0.1MF		50V
C301	1-124-994-11	ELECT	100MF	20%	10V
C302	1-164-159-11	CERAMIC	0.1MF		50V
C303	1-162-179-11	(EXCEPT US)...CERAMIC	0.1MF		50V
C303	1-162-851-11	(US).....CERAMIC	0.1MF	20%	16V
C304	1-162-294-31	(EXCEPT US)...CERAMIC	0.001MF	10%	50V
C305	1-124-768-11	ELECT	4.7MF	20%	50V
C310	1-124-994-11	ELECT	100MF	20%	10V
C311	1-162-179-11	(EXCEPT US)...CERAMIC	0.1MF		50V
C311	1-164-159-11	(US).....CERAMIC	0.1MF		50V
C351	1-162-291-31	(US).....CERAMIC	560PF	10%	50V
C401	1-110-341-11	(EXCEPT US)...MYLAR	330PF	5%	50V
C402	1-110-335-11	(EXCEPT US)...MYLAR	100PF	5%	50V
C402	1-136-232-11	(US).....FILM	0.0043MF	5%	100V

Ref.No.	Part No.	Description			
C403	1-110-335-11	(EXCEPT US)...MYLAR	100PF	5%	50V
C403	1-124-910-11	(US).....ELECT	47MF	20%	50V
C404	1-136-227-11	(US).....FILM	0.0011MF	5%	100V
C404	1-136-232-11	(EXCEPT US)...FILM	0.0043MF	5%	100V
C405	1-130-468-00	(US).....MYLAR	560PF	5%	50V
C405	1-136-227-11	(EXCEPT US)...FILM	0.0011MF	5%	100V
C406	1-124-918-11	(EXCEPT US)...ELECT	47MF	20%	63V
C406	1-164-159-11	(US).....CERAMIC	0.1MF		50V
C407	1-124-478-11	(US).....ELECT	100MF	20%	25V
C407	1-130-471-00	(EXCEPT US)...MYLAR	0.001MF	5%	50V
C408	1-124-478-11	(US)...ELECT	100MF	20%	25V
C409	1-164-159-11	(US)...CERAMIC	0.1MF		50V
C410	1-124-713-11	ELECT	470MF	20%	35V
C411	1-136-250-11	(US)...FILM	0.001MF	5%	100V
C412	1-136-250-11	(US)...FILM	0.001MF	5%	100V
C451	1-126-012-11	ELECT	470MF	20%	16V
C452	1-130-471-00	(EXCEPT US)...MYLAR	0.001MF	5%	50V
C452	1-162-291-31	(US).....CERAMIC	560PF	10%	50V
C455	1-161-377-00	CERAMIC	0.0047MF	20%	16V
C501	1-110-341-11	(EXCEPT US)...MYLAR	330PF	5%	50V
C502	1-110-335-11	(EXCEPT US)...MYLAR	100PF	5%	50V
C502	1-136-232-11	(US).....FILM	0.0043MF	5%	100V
C503	1-110-335-11	(EXCEPT US)...MYLAR	100PF	5%	50V
C503	1-124-910-11	(US).....ELECT	47MF	20%	50V
C504	1-136-227-11	(US).....FILM	0.0011MF	5%	100V
C504	1-136-232-11	(EXCEPT US)...FILM	0.0043MF	5%	100V
C505	1-130-468-00	(US).....MYLAR	560PF	5%	50V
C505	1-136-227-11	(EXCEPT US)...FILM	0.0011MF	5%	100V
C506	1-124-478-11	(US).....ELECT	100MF	20%	25V
C506	1-124-918-11	(EXCEPT US)...ELECT	47MF	20%	63V
C507	1-130-471-00	(EXCEPT US)...MYLAR	0.001MF	5%	50V
C507	1-164-159-11	(US).....CERAMIC	0.1MF		50V
C508	1-164-159-11	(US)...CERAMIC	0.1MF		50V
C509	1-124-478-11	(US)...ELECT	100MF	20%	25V
C510	1-124-713-11	ELECT	470MF	20%	35V
C511	1-136-250-11	(US)...FILM	0.001MF	5%	100V
C512	1-136-250-11	(US)...FILM	0.001MF	5%	100V
C551	1-126-012-11	ELECT	470MF	20%	16V
C552	1-130-471-00	(EXCEPT US)...MYLAR	0.001MF	5%	50V
C552	1-162-291-31	(US).....CERAMIC	560PF	10%	50V
C555	1-161-377-00	CERAMIC	0.0047MF	20%	16V
C556	1-164-159-11	CERAMIC	0.1MF		50V
C801	1-164-159-11	CERAMIC	0.1MF		50V
C802	1-164-159-11	CERAMIC	0.1MF		50V
C803	1-164-159-11	CERAMIC	0.1MF		50V
C901	1-126-017-11	ELECT	6800MF	20%	16V
C902	1-126-842-11	ELECT	4700MF	20%	16V
C903	1-126-059-11	ELECT	10MF	20%	50V
C904	1-162-291-31	CERAMIC	560PF	10%	50V
C905	1-124-045-00	ELECT	4.7MF	20%	50V
C906	1-124-360-00	ELECT	1000MF	20%	16V
C907	1-124-360-00	ELECT	1000MF	20%	16V
C908	1-126-301-11	(US)...ELECT	1MF	20%	50V
C909	1-126-534-11	ELECT	47000MF		5.5V
C910	1-126-880-11	ELECT	100MF	20%	63V

Ref.No.	Part No.	Description
C911	1-124-122-11	ELECT 100MF 20% 50V
C912	1-124-122-11	ELECT 100MF 20% 50V
C913	1-126-012-11	(US)...ELECT 470MF 20% 16V
C914	1-162-851-11	(US)...CERAMIC 0.1MF 20% 16V
C914	1-162-179-11	(EXCEPT US)...CERAMIC 0.1MF 50V
C951	1-126-012-11	(EXCEPT US)...ELECT 470MF 20% 16V
C952	1-126-646-51	(EXCEPT US)...ELECT 470MF 20% 25V
C953	1-124-120-11	(EXCEPT US)...ELECT 220MF 20% 25V
C991	1-161-744-00	CERAMIC 0.01MF 400V
CN1	*1-564-721-21	PIN, CONNECTOR (SMALL TYPE) 5P
CN2	*1-564-720-11	PIN, CONNECTOR (SMALL TYPE) 4P
CN3	*1-564-724-11	PIN, CONNECTOR (SMALL TYPE) 8P
CN101	*1-564-710-11	PIN, CONNECTOR (SMALL TYPE) 8P
CN102	*1-564-706-31	PIN, CONNECTOR (SMALL TYPE) 4P
CN103	*1-564-707-11	PIN, CONNECTOR (SMALL TYPE) 5P
CN104	*1-564-339-61	PIN, CONNECTOR 5P
CN301	*1-564-342-11	PIN, CONNECTOR 8P
CN302	*1-564-340-00	PIN, CONNECTOR 6P
CN303	*1-564-705-11	PIN, CONNECTOR (SMALL TYPE) 3P
CN304	*1-564-705-11	PIN, CONNECTOR (SMALL TYPE) 3P
CN305	*1-564-705-11	PIN, CONNECTOR (SMALL TYPE) 3P
CN451	*1-564-722-11	PIN, CONNECTOR (SMALL TYPE) 6P
CN452	*1-564-705-11	PIN, CONNECTOR (SMALL TYPE) 3P
CN901	*1-564-509-11	PLUG, CONNECTOR 6P
CN902	*1-564-340-00	PIN, CONNECTOR 6P
CNP1	1-568-795-11	SOCKET, CONNECTOR 12P
D201	8-719-107-94	(EXCEPT US)...DIODE 1SS202-1
D202	8-719-114-29	(EXCEPT US)...DIODE RD5.1JS-B1
D203	8-719-210-23	(EXCEPT US)...DIODE 11EQS04-TA1B
D250	8-719-107-94	(EXCEPT US)...DIODE 1SS202-1
D251	8-719-107-94	(EXCEPT US)...DIODE 1SS202-1
D252	8-719-107-94	(EXCEPT US)...DIODE 1SS202-1
D351	8-719-107-94	DIODE 1SS202-1
D801	8-719-107-94	DIODE 1SS202-1
D802	8-719-107-94	DIODE 1SS202-1
D803	8-719-107-94	DIODE 1SS202-1
D804	8-719-107-94	DIODE 1SS202-1
D805	8-719-107-94	DIODE 1SS202-1
D806	8-719-107-94	DIODE 1SS202-1
D807	8-719-107-94	DIODE 1SS202-1
D808	8-719-907-81	DIODE 8G5535S
D809	8-719-907-75	DIODE AA5534S
D901	8-719-200-77	DIODE 10E2N
D902	8-719-200-77	DIODE 10E2N
D903	8-719-200-77	DIODE 10E2N
D904	8-719-200-77	DIODE 10E2N
D906	8-719-107-94	(US)...DIODE 1SS202-1
D907	8-719-107-94	DIODE 1SS202-1
D908	8-719-934-31	DIODE HZS36-3L
D909	8-719-200-77	DIODE 10E2N
D910	8-719-933-57	DIODE HZS9B2L
D911	8-719-107-94	(US)...DIODE 1SS202-1
D912	8-719-107-94	(US)...DIODE 1SS202-1
D913	8-719-107-94	(US)...DIODE 1SS202-1
D914	8-719-107-94	(US)...DIODE 1SS202-1
D915	8-719-109-75	(US)...DIODE RD4.3ES-B2

Ref.No.	Part No.	Description
D916	8-719-107-94	DIODE 1SS202-1
D952	8-719-200-77	(EXCEPT US)...DIODE 10E2N
D953	8-719-200-77	(EXCEPT US)...DIODE 10E2N
FLD801	1-519-554-11	INDICATOR TUBE, FLUORESCENT
IC101	8-752-037-33	IC CXA1372Q
IC102	8-752-035-28	IC CXA1291P
IC103	8-752-035-28	IC CXA1291P
IC201	8-752-333-31	IC CXD2500Q
IC202	8-752-328-61	IC CXD1244S
IC203	8-752-334-87	(EXCEPT US)...IC CXD2552Q
IC203	8-759-990-80	(US)...IC CXD8097S
IC204	8-759-977-71	IC GP1F31T
IC205	8-752-334-77	(EXCEPT US)...IC CXD2553S
IC206	8-759-233-63	(EXCEPT US)...IC TC74HCU04AP
IC207	8-759-604-36	(EXCEPT US)...IC M5F78M08L
IC301	8-759-634-61	IC M37450M8-137FP
IC302	8-759-822-50	IC LC3564PL-15
IC303	8-759-962-08	IC BA6208
IC401	8-759-982-03	(EXCEPT US)...IC RC5532DD
IC401	8-759-998-23	(US)...IC AD1860N-0
IC402	8-759-998-23	(US)...IC AD1860N-0
IC403	8-759-982-03	(US)...IC RC5532DD
IC451	8-759-981-85	IC NJM4556D
IC501	8-759-982-03	(EXCEPT US)...IC RC5532DD
IC501	8-759-998-23	(US)...IC AD1860N-0
IC502	8-759-998-23	(US)...IC AD1860N-0
IC503	8-759-982-03	(US)...IC RC5532DD
IC801	8-759-998-54	IC MSC62408-005GS-K
IC802	8-749-920-83	IC GP1U52XB
IC901	8-759-630-21	IC M5290P-16
J401	1-568-761-11	JACK, PIN 4P (LINE OUT)
J402	1-568-519-21	(US,Canadian)...JACK, LARGE TYPE
J402	1-568-519-41	(AEP,UK,E,Australian)...JACK, LARGE TYPE (PHONES)
M1	X-4917-523-1	MOTOR ASSY, SPINDLE
M2	X-4917-504-1	MOTOR ASSY, SLED
M251	A-4608-362-A	MOTOR (L) ASSY (LOADING)
PS902	1-532-984-11	(AEP,UK,E,Australian)...LINK, IC (ICP-N50)
Q101	8-729-900-89	TRANSISTOR DTC144ES
Q201	8-729-216-13	(EXCEPT US)...TRANSISTOR 2SK161GR
Q202	8-729-905-67	(EXCEPT US)...TRANSISTOR 2SD1944-K
Q204	8-729-900-61	(EXCEPT US)...TRANSISTOR DTA114ES
Q206	8-729-900-61	(EXCEPT US)...TRANSISTOR DTA114ES
Q301	8-729-900-80	TRANSISTOR DTC114ES
Q351	8-729-115-28	(EXCEPT US)...TRANSISTOR BN1L3Z-K
Q351	8-729-900-61	(US)...TRANSISTOR DTA114ES
Q352	8-729-119-78	(EXCEPT US)...TRANSISTOR 2SC2785-HFE
Q352	8-729-900-80	(US)...TRANSISTOR DTC114ES
Q353	8-729-119-78	(EXCEPT US)...TRANSISTOR 2SC2785-HFE
Q401	8-729-107-84	(US)...TRANSISTOR 2SC3623A-L
Q401	8-729-201-05	(EXCEPT US)...TRANSISTOR 2SC2878B
Q402	8-729-107-84	(US)...TRANSISTOR 2SC3623A-L
Q501	8-729-107-84	(US)...TRANSISTOR 2SC3623A-L
Q501	8-729-201-05	(EXCEPT US)...TRANSISTOR 2SC2878B

Ref.No.	Part No.	Description
Q502	8-729-107-84	(US)...TRANSISTOR 2SC3623A-L
Q801	8-729-900-45	TRANSISTOR DTC114EF
Q802	8-729-900-45	TRANSISTOR DTC114EF
Q803	8-729-900-45	TRANSISTOR DTC114EF
Q804	8-729-900-45	TRANSISTOR DTC114EF
Q901	8-729-821-72	TRANSISTOR 2SD1913SA-RS
Q902	8-729-111-67	TRANSISTOR 2SB1094-L
Q903	8-729-140-96	TRANSISTOR 2SD774-34
Q905	8-729-115-28	TRANSISTOR BN1L3Z-K
Q906	8-729-900-89	TRANSISTOR DTC144ES
R101	1-249-428-11	CARBON 8.2K 5% 1/4W
R102	1-247-887-00	CARBON 220K 5% 1/4W
R103	1-249-434-11	CARBON 27K 5% 1/4W
R104	1-249-441-11	CARBON 100K 5% 1/4W
R105	1-249-441-11	CARBON 100K 5% 1/4W
R106	1-249-438-11	CARBON 56K 5% 1/4W
R107	1-249-427-11	CARBON 6.8K 5% 1/4W
R108	1-249-423-11	CARBON 3.3K 5% 1/4W
R109	1-247-896-11	CARBON 510K 5% 1/4W
R110	1-247-887-00	CARBON 220K 5% 1/4W
R112	1-249-429-11	CARBON 10K 5% 1/4W
R113	1-249-441-11	CARBON 100K 5% 1/4W
R114	1-247-854-11	CARBON 9.1K 5% 1/4W
R115	1-247-854-11	CARBON 9.1K 5% 1/4W
R116	1-249-393-11	CARBON 10 5% 1/4W
R118	1-249-393-11	CARBON 10 5% 1/4W
R119	1-249-423-11	CARBON 3.3K 5% 1/4W
R120	1-247-881-00	CARBON 120K 5% 1/4W
R122	1-249-429-11	CARBON 10K 5% 1/4W
R123	1-247-883-00	CARBON 150K 5% 1/4W
R124	1-247-878-00	CARBON 91K 5% 1/4W
R125	1-247-883-00	CARBON 150K 5% 1/4W
R126	1-249-433-11	CARBON 22K 5% 1/4W
R127	1-249-393-11	CARBON 10 5% 1/4W
R128	1-247-881-00	CARBON 120K 5% 1/4W
R129	1-247-881-00	CARBON 120K 5% 1/4W
R130	1-249-441-11	CARBON 100K 5% 1/4W
R131	1-249-441-11	CARBON 100K 5% 1/4W
R132	1-249-393-11	CARBON 10 5% 1/4W
R135	1-247-868-11	CARBON 36K 5% 1/4W
R136	1-249-432-11	CARBON 18K 5% 1/4W
R137	1-247-868-11	CARBON 36K 5% 1/4W
R138	1-249-437-11	CARBON 47K 5% 1/4W
R139	1-249-441-11	CARBON 100K 5% 1/4W
R140	1-249-437-11	CARBON 47K 5% 1/4W
R141	1-249-441-11	CARBON 100K 5% 1/4W
R142	1-249-423-11	CARBON 3.3K 5% 1/4W
R143	1-247-881-00	CARBON 120K 5% 1/4W
R150	1-249-417-11	CARBON 1K 5% 1/4W
R151	1-247-881-00	CARBON 120K 5% 1/4W
R152	1-249-393-11	CARBON 10 5% 1/4W
R201	1-249-423-11	CARBON 3.3K 5% 1/4W
R202	1-249-423-11	CARBON 3.3K 5% 1/4W
R203	1-249-429-11	CARBON 10K 5% 1/4W
R204	1-249-429-11	CARBON 10K 5% 1/4W
R205	1-249-429-11	CARBON 10K 5% 1/4W
R206	1-249-435-11	CARBON 33K 5% 1/4W
R209	1-249-413-11	CARBON 470 5% 1/4W

Ref.No.	Part No.	Description
R210	1-249-413-11	CARBON 470 5% 1/4W
R211	1-249-413-11	CARBON 470 5% 1/4W
R212	1-249-417-11	CARBON 1K 5% 1/4W
R213	1-249-413-11	CARBON 470 5% 1/4W
R214	1-249-413-11	CARBON 470 5% 1/4W
R215	1-249-413-11	CARBON 470 5% 1/4W
R216	1-249-413-11	CARBON 470 5% 1/4W
R217	1-249-411-11	CARBON 330 5% 1/4W
R218	1-249-411-11	(US).....CARBON 330 5% 1/4W
R219	1-249-411-11	(US).....CARBON 330 5% 1/4W
R219	1-249-423-11	(EXCEPT US)...CARBON 3.3K 5% 1/4W
R220	1-249-405-11	(US).....CARBON 100 5% 1/4W
R220	1-249-411-11	(EXCEPT US)...CARBON 330 5% 1/4W
R221	1-249-407-11	(US).....CARBON 150 5% 1/4W
R221	1-249-417-11	(EXCEPT US)...CARBON 1K 5% 1/4W
R222	1-247-903-00	(US).....CARBON 1M 5% 1/4W
R223	1-247-848-11	(EXCEPT US)...CARBON 5.1K 5% 1/4W
R223	1-249-411-11	(US).....CARBON 330 5% 1/4W
R224	1-249-411-11	(US).....CARBON 330 5% 1/4W
R225	1-249-411-11	(US).....CARBON 330 5% 1/4W
R226	1-249-405-11	(US).....CARBON 100 5% 1/4W
R230	1-249-417-11	CARBON 1K 5% 1/4W
R237	1-249-409-11	(US).....CARBON 220 5% 1/4W
R240	1-249-417-11	(US).....CARBON 1K 5% 1/4W
R250	1-247-896-11	(EXCEPT US)...CARBON 510K 5% 1/4W
R252	1-249-428-11	(EXCEPT US)...CARBON 8.2K 5% 1/4W
R253	1-249-436-11	(EXCEPT US)...CARBON 39K 5% 1/4W
R255	1-249-428-11	(EXCEPT US)...CARBON 8.2K 5% 1/4W
R256	1-249-436-11	(EXCEPT US)...CARBON 39K 5% 1/4W
R301	1-247-903-00	CARBON 1M 5% 1/4W
R302	1-249-411-11	CARBON 330 5% 1/4W
R303	1-249-429-11	CARBON 10K 5% 1/4W
R304	1-249-429-11	CARBON 10K 5% 1/4W
R305	1-249-429-11	CARBON 10K 5% 1/4W
R306	1-249-429-11	CARBON 10K 5% 1/4W
R308	1-249-429-11	CARBON 10K 5% 1/4W
R309	1-249-429-11	CARBON 10K 5% 1/4W
R310	1-249-429-11	CARBON 10K 5% 1/4W
R311	1-249-429-11	CARBON 10K 5% 1/4W
R312	1-249-429-11	CARBON 10K 5% 1/4W
R313	1-249-417-11	CARBON 1K 5% 1/4W
R314	1-249-429-11	CARBON 10K 5% 1/4W
R315	1-249-429-11	CARBON 10K 5% 1/4W
R316	1-249-417-11	CARBON 1K 5% 1/4W
R317	1-249-429-11	CARBON 10K 5% 1/4W
R318	1-249-409-11	CARBON 220 5% 1/4W
R319	1-249-429-11	CARBON 10K 5% 1/4W
R320	1-249-429-11	CARBON 10K 5% 1/4W
R321	1-249-429-11	CARBON 10K 5% 1/4W
R322	1-249-429-11	CARBON 10K 5% 1/4W
R331	1-249-413-11	CARBON 470 5% 1/4W
R351	1-249-433-11	(EXCEPT US)...CARBON 22K 5% 1/4W
R351	1-249-441-11	(US).....CARBON 100K 5% 1/4W
R352	1-249-441-11	(EXCEPT US)...CARBON 100K 5% 1/4W
R353	1-249-401-11	(EXCEPT US)...CARBON 47 5% 1/4W

Ref.No.	Part No.	Description			
R401	1-249-428-11	(EXCEPT US)...CARBON	8.2K	5%	1/4W
R401	1-249-431-11	(US).....CARBON	15K	5%	1/4W
R402	1-249-419-11	(US).....CARBON	1.5K	5%	1/4W
R402	1-249-425-11	(EXCEPT US)...CARBON	4.7K	5%	1/4W
R403	1-249-419-11	(US).....CARBON	1.5K	5%	1/4W
R403	1-249-428-11	(EXCEPT US)...CARBON	8.2K	5%	1/4W
R404	1-247-891-00	(US).....CARBON	330K	5%	1/4W
R404	1-249-425-11	(EXCEPT US)...CARBON	4.7K	5%	1/4W
R405	1-249-409-11	(US).....CARBON	220	5%	1/4W
R405	1-249-432-11	(EXCEPT US)...CARBON	18K	5%	1/4W
R406	1-249-409-11	(US).....CARBON	220	5%	1/4W
R406	1-249-432-11	(EXCEPT US)...CARBON	18K	5%	1/4W
R407	1-249-419-11	(EXCEPT US)...CARBON	1.5K	5%	1/4W
R407	1-249-423-11	(US).....CARBON	3.3K	5%	1/4W
R408	1-249-419-11	(EXCEPT US)...CARBON	1.5K	5%	1/4W
R408	1-249-423-11	(US).....CARBON	3.3K	5%	1/4W
R409	1-249-405-11	(EXCEPT US)...CARBON	100	5%	1/4W
R409	1-249-409-11	(US).....CARBON	220	5%	1/4W
R410	1-247-866-11	(US).....CARBON	30K	5%	1/4W
R410	1-247-891-00	(EXCEPT US)...CARBON	330K	5%	1/4W
R411	1-247-866-11	(US).....CARBON	30K	5%	1/4W
R411	1-249-405-11	(EXCEPT US)...CARBON	100	5%	1/4W
R412	1-249-393-11	(EXCEPT US)...CARBON	10	5%	1/4W
R451	1-249-435-11	CARBON	33K	5%	1/4W
R452	1-249-429-11	CARBON	10K	5%	1/4W
R453	1-249-435-11	CARBON	33K	5%	1/4W
R454	1-249-402-11	CARBON	56	5%	1/4W
R455	1-249-405-11	(EXCEPT US)...CARBON	100	5%	1/4W
R455	1-249-409-11	(US).....CARBON	220	5%	1/4W
R501	1-249-428-11	(EXCEPT US)...CARBON	8.2K	5%	1/4W
R501	1-249-431-11	(US).....CARBON	15K	5%	1/4W
R502	1-249-419-11	(US).....CARBON	1.5K	5%	1/4W
R502	1-249-425-11	(EXCEPT US)...CARBON	4.7K	5%	1/4W
R503	1-249-419-11	(US).....CARBON	1.5K	5%	1/4W
R503	1-249-428-11	(EXCEPT US)...CARBON	8.2K	5%	1/4W
R504	1-247-891-00	(US).....CARBON	330K	5%	1/4W
R504	1-249-425-11	(EXCEPT US)...CARBON	4.7K	5%	1/4W
R505	1-249-409-11	(US).....CARBON	220	5%	1/4W
R505	1-249-432-11	(EXCEPT US)...CARBON	18K	5%	1/4W
R506	1-249-409-11	(US).....CARBON	220	5%	1/4W
R506	1-249-432-11	(EXCEPT US)...CARBON	18K	5%	1/4W
R507	1-249-419-11	(EXCEPT US)...CARBON	1.5K	5%	1/4W
R507	1-249-423-11	(US).....CARBON	3.3K	5%	1/4W
R508	1-249-419-11	(EXCEPT US)...CARBON	1.5K	5%	1/4W
R508	1-249-423-11	(US).....CARBON	3.3K	5%	1/4W
R509	1-249-405-11	(EXCEPT US)...CARBON	100	5%	1/4W
R509	1-249-409-11	(US).....CARBON	220	5%	1/4W
R510	1-247-866-11	(US).....CARBON	30K	5%	1/4W
R510	1-247-891-00	(EXCEPT US)...CARBON	330K	5%	1/4W
R511	1-247-866-11	(US).....CARBON	30K	5%	1/4W
R511	1-249-405-11	(EXCEPT US)...CARBON	100	5%	1/4W

Ref.No.	Part No.	Description			
R512	1-249-393-11	(EXCEPT US)...CARBON	10	5%	1/4W
R551	1-249-435-11	CARBON	33K	5%	1/4W
R552	1-249-429-11	CARBON	10K	5%	1/4W
R553	1-249-435-11	CARBON	33K	5%	1/4W
R554	1-249-402-11	CARBON	56	5%	1/4W
R555	1-249-405-11	(EXCEPT US)...CARBON	100	5%	1/4W
R555	1-249-409-11	(US).....CARBON	220	5%	1/4W
R801	1-247-903-00	CARBON	1M	5%	1/4W
R802	1-249-406-11	CARBON	120	5%	1/4W
R803	1-249-409-11	CARBON	220	5%	1/4W
R804	1-249-429-11	CARBON	10K	5%	1/4W
R805	1-249-429-11	CARBON	10K	5%	1/4W
R806	1-249-441-11	CARBON	100K	5%	1/4W
R807	1-249-441-11	CARBON	100K	5%	1/4W
R808	1-249-417-11	CARBON	1K	5%	1/4W
R901	1-249-425-11	CARBON	4.7K	5%	1/4W
R902	1-249-425-11	CARBON	4.7K	5%	1/4W
R903	1-249-423-11	CARBON	3.3K	5%	1/4W
R904	1-249-405-11	CARBON	100	5%	1/4W
R905	△ 1-212-869-00	FUSIBLE	33	5%	1/4W F
R906	1-249-424-11	CARBON	3.9K	5%	1/4W
R907	1-249-433-11	CARBON	22K	5%	1/4W
R908	1-249-433-11	CARBON	22K	5%	1/4W
R909	1-249-433-11	(US)...CARBON	22K	5%	1/4W
R910	1-249-433-11	(US)...CARBON	22K	5%	1/4W
R911	1-247-733-11	(US,Canadian,E) ...CARBON	33	5%	1/2W
R911	1-249-516-11	(AEP,UK,Australian) ...CARBON	33	5%	1/4W
R912	1-247-733-11	(US,Canadian,E)) ...CARBON	33	5%	1/2W
R912	1-249-516-11	(AEP,UK,Australian) ...CARBON	33	5%	1/4W
R913	1-249-413-11	(US)...CARBON	470	5%	1/4W
R914	1-249-429-11	CARBON	10K	5%	1/4W
R951	1-247-727-11	(EXCEPT US)...CARBON	10	5%	1/2W
RV201	1-228-994-00	RES, ADJ, CARBON	10K		
RV202	1-228-994-00	RES, ADJ, CARBON	10K		
RV451	1-238-775-11	RES, VAR, CARBON	10KX3		(LINE OUT/PHONE LEVEL)
RY351	1-515-787-11	RELAY			
RY901	1-515-789-11	RELAY			
S1	1-572-085-11	SWITCH, LEAF			
S251	1-571-736-11	SWITCH, LEAF (IN)			
S252	1-571-736-11	SWITCH, LEAF (OUT)			
S801	1-554-596-21	SWITCH, KEY BOARD (OPEN/CLOSE)			
S803	1-554-596-21	SWITCH, KEY BOARD (▷)			
S804	1-554-596-21	SWITCH, KEY BOARD (PEACK SEARCH)			
S805	1-554-596-21	SWITCH, KEY BOARD (TIME/MEMO)			
S806	1-554-596-21	SWITCH, KEY BOARD (REPEAT)			
S807	1-554-596-21	SWITCH, KEY BOARD (FADER)			
S808	1-554-596-21	SWITCH, KEY BOARD (5)			
S809	1-554-596-21	SWITCH, KEY BOARD (10)			
S810	1-554-596-21	SWITCH, KEY BOARD (15)			
S811	1-554-596-21	SWITCH, KEY BOARD (20)			
S812	1-554-596-21	SWITCH, KEY BOARD (▶▶)			
S813	1-554-596-21	SWITCH, KEY BOARD (▶▶)			

**Note:**  
The components identified by mark △ or dotted line with mark △ are critical for safety. Replace only with part number specified.



**Note:**  
Les composants identifiés par une marque △ sont critiques pour la sécurité. Ne les remplacer que par une pièce portant le numéro spécifié.

Ref.No.	Part No.	Description
S814	1-554-596-21	SWITCH, KEY BOARD (TIME SET)
S815	1-554-596-21	SWITCH, KEY BOARD (4)
S816	1-554-596-21	SWITCH, KEY BOARD (9)
S817	1-554-596-21	SWITCH, KEY BOARD (14)
S818	1-554-596-21	SWITCH, KEY BOARD (19)
S819	1-554-596-21	SWITCH, KEY BOARD (44)
S820	1-554-596-21	SWITCH, KEY BOARD (KK)
S821	1-554-596-21	SWITCH, KEY BOARD (EDIT/TIME FADE)
S822	1-554-596-21	SWITCH, KEY BOARD (3)
S823	1-554-596-21	SWITCH, KEY BOARD (8)
S824	1-554-596-21	SWITCH, KEY BOARD (13)
S825	1-554-596-21	SWITCH, KEY BOARD (18)
S827	1-554-596-21	SWITCH, KEY BOARD (ERASE)
S828	1-554-596-21	SWITCH, KEY BOARD (FILE)
S829	1-554-596-21	SWITCH, KEY BOARD (2)
S830	1-554-596-21	SWITCH, KEY BOARD (7)
S831	1-554-596-21	SWITCH, KEY BOARD (12)
S832	1-554-596-21	SWITCH, KEY BOARD (17)
S833	1-554-596-21	SWITCH, KEY BOARD (■)
S834	1-554-596-21	SWITCH, KEY BOARD (>20)
S835	1-554-596-21	SWITCH, KEY BOARD (CLEAR)
S836	1-554-596-21	SWITCH, KEY BOARD (1)
S837	1-554-596-21	SWITCH, KEY BOARD (6)
S838	1-554-596-21	SWITCH, KEY BOARD (11)
S839	1-554-596-21	SWITCH, KEY BOARD (16)
S840	1-554-596-21	SWITCH, KEY BOARD (□)
S842	1-554-596-21	SWITCH, KEY BOARD (CHECK)
S843	1-554-596-21	SWITCH, KEY BOARD (CONTINUE)
S844	1-554-596-21	SWITCH, KEY BOARD (SHUFFLE)
S845A	1-554-481-00	SWITCH, SLIDE (TIMER)
S845B	1-554-596-21	SWITCH, KEY BOARD (PROGRAM)
S846	1-554-596-21	SWITCH, KEY BOARD (C.INDEX)
S847	1-554-596-21	SWITCH, KEY BOARD (LEVEL FILE)
S848	1-554-596-21	SWITCH, KEY BOARD (MULTI PGM)
S849	1-554-596-21	SWITCH, KEY BOARD (FILE RECALL)
S991	1-570-156-11	SWITCH, PUSH (AC POWER)(1 KEY)(POWER)
S992	△.1-526-576-51	(E)...SELECTOR, POWER VOLTAGE (VOLTAGE SELECTOR)
T991	△.1-449-578-11	(US,Canadian).....TRANSFORMER, POWER
T991	△.1-449-579-11	(AEP,UK,Australian)..TRANSFORMER, POWER
T991	△.1-449-580-11	(E).....TRANSFORMER, POWER
THP901	1-808-065-11	(AEP,UK,E,Australian) ...THERMISTOR, POSITIVE
TN991	*1-535-771-11	TERMINAL
TN992	*1-535-771-11	TERMINAL

Ref.No.	Part No.	Description
X201	1-567-926-11	(US)...VIBRATOR, CRYSTAL (16.9344MHz)
X201	1-577-685-11	(EXCEPT US)...FILTER, CRYSTAL (16.9344MHz)
X202	1-577-686-11	(EXCEPT US)...VIBRATOR, CRYSTAL (45.1584MHz)
X301	1-577-377-11	VIBRATOR, CERAMIC (10MHz)
X801	1-577-082-11	VIBRATOR, CERAMIC (4.0MHz)

ACCESSORY & PACKING MATERIAL

1-465-277-11	REMOTE COMMANDER (RM-D590)
1-559-533-11	CORD, CONNECTION
3-750-847-11	(EXCEPT US)...MANUAL, INSTRUCTION
3-750-847-21	(US).....MANUAL, INSTRUCTION
3-750-847-41	(AEP).....MANUAL, INSTRUCTION
*3-704-343-01	SHEET (STANDARD), PROTECTION
4-925-788-01	COVER, BATTERY
*4-929-016-01	STOPPER, DISC TABLE
*4-934-088-01	CUSHION
*4-934-089-11	INDIVIDUAL CARTON

**Note:**  
The components identified by mark  or dotted line with mark  are critical for safety. Replace only with part number specified.

**Note:**  
Les composants identifiés par une marque  sont critiques pour la sécurité. Ne les remplacer que par une pièce portant le numéro spécifié.